



NVIDIA DOCA East-West Overlay Encryption Application

Table of contents

1. Introduction

2. System Design

3. Application Architecture

4. DOCA Libraries

5. Configuration Flow

6. Running the Application

7. References

This guide describes IPsec-based strongSwan solution on top of NVIDIA® BlueField® DPU.

Note

If your target application utilizes 100Gb/s or higher bandwidth, where a substantial part of the bandwidth is allocated for IPsec traffic, please refer to the *NVIDIA BlueField-2 DPUs Product Release Notes* to learn about a potential bandwidth limitation. To access the relevant product release notes, please contact your NVIDIA sales representative.

1. Introduction

IPsec is used to set up encrypted connections between different devices. It helps keep data sent over public networks secure. IPsec is often used to set up VPNs, and it works by encrypting IP packets as well as authenticating the packets' originator.

IPsec contains the following main modules:

- Key exchange – a key is a string of random bytes that can be used for encryption and decryption of messages. IPsec sets up keys with a key exchange between the connected devices, so that each device can decrypt the other device's messages.
- Authentication – IPsec provides authentication for each packet which ensures that they come from a trusted source.
- Encryption – IPsec encrypts the payloads within each packet and possibly, based on the transport mode, the packet's IP header.
- Decryption – at the other end of the communication, packets are decrypted by the IPsec supported node.

IPsec supports two types of headers:

- Authentication header (AH) – AH protocol ensures that packets are from a trusted source. AH does not provide any encryption.
- Encapsulating security protocol (ESP) – ESP encrypts the payload for each packet as well as the IP header depending on the transport mode. ESP adds its own header

and a trailer to each data packet.

IPsec support two types of transport mode:

- IPsec tunnel mode – used between two network nodes, each acting as tunnel initiator/terminator on a public network. In this mode, the original IP header and payload are both encrypted. Since the IP header is encrypted, an IP tunnel is added for network forwarding. At each end of the tunnel, the routers decrypt the IP headers to route the packets to their destinations.
- Transport mode – the payload of each packet is encrypted, but the original IP header is not. Intermediary network nodes are therefore able to view the destination of each packet and route the packet, unless a separate tunneling protocol is used.

strongSwan is an open-source IPsec-based VPN solution. For more information, refer to [strongSwan documentation](#).

2. System Design

IPsec packet offload offloads both IPsec crypto (encrypt/decrypt) and IPsec encapsulation to the hardware.

The deployment model allows the IPsec offload to be transparent to the host with the benefits of securing legacy workloads (no dependency on host SW stack) and to zero CPU utilization on host.

IPsec packet offload configuration works with and is transparent to OVS offload. This means all packets from OVS offload are encrypted by IPsec rules.

The following figure illustrates the interaction between IPsec packet offload and OVS VXLAN offload.

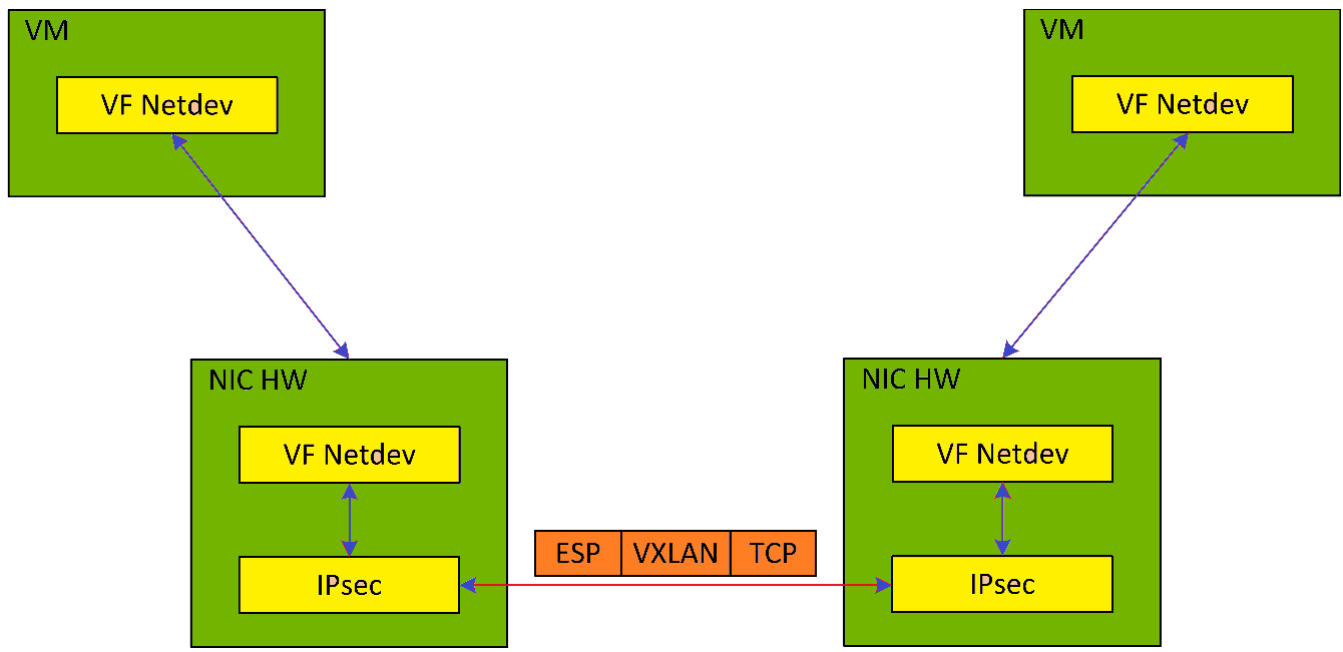

Note

IPsec packet offload is only supported on Ubuntu Bluefield kernel 5.15

Note

OVS offload and IPsec IPv6 do not work together.

3. Application Architecture

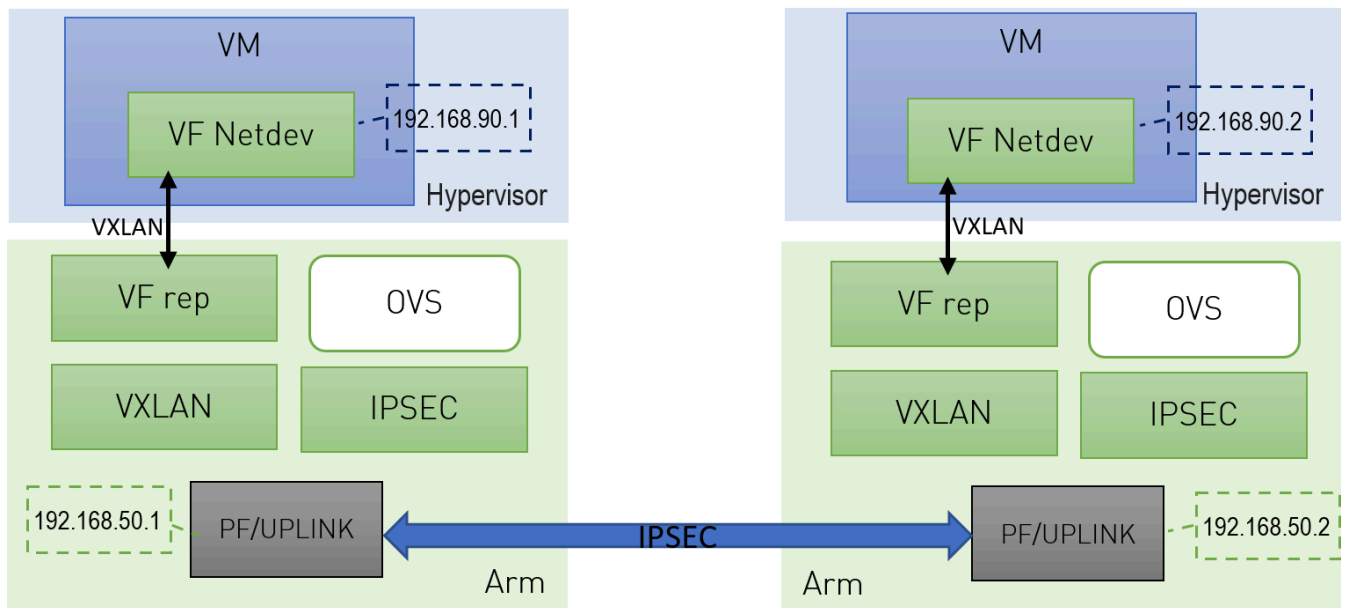

1. Configure strongSwan IPsec offload using `swanctl.conf` configuration file.
2. Traffic is sent from the host through BlueField.
3. Using OVS, the packets are encapsulated on ingress using tunnel protocols (VXLAN for example) to match IPsec configuration by strongSwan.
4. Set by strongSwan configuration file, traffic will be encrypted using the hardware offload.
5. Egress flow is decryption first, decapsulation of the tunnel header and forward to the relevant physical function.

4. DOCA Libraries

N/A

5. Configuration Flow

The following section provides information on manually configuring IPsec packet offload in general and on using OVS IPsec with strongSwan specifically.

Note

There is a script, `east_west_overlay_encryption.sh` which performs the steps in this section automatically.

If you are working directly with the `ip xfrm` tool, use `/opt/mellanox/iproute2/sbin/ip` to benefit from IPsec packet offload support.

There are two parts in the configuration flow

1. Enabling IPsec packet offload mode.
2. Configuring the IPsec OVS bridge using one of three modes of authentication.

Note

An alternative for step two is configuring `swanctl.conf` files (configuration files for strongSwan) manually and using strongSwan directly instead of using IPsec OVS (which automatically generates `swanctl.conf` files) as explained in section "[Configuring OVS IPsec Using strongSwan Manually](#)".

5.1 Enabling IPsec Packet Offload

This section explicitly enables IPsec packet offload on the Arm cores before setting up offload-aware IPsec tunnels.

Note

If an OVS VXLAN tunnel configuration already exists, stop `openvswitch` service prior to performing the steps below and restart the service afterwards.

Explicitly enable IPsec full offload on the Arm cores.

1. Set `IPSEC_FULL_OFFLOAD="yes"` in `/etc/mellanox/mlnx-bf.conf`.

Note

If `IPSEC_FULL_OFFLOAD` does not appear in `/etc/mellanox/mlnx-bf.conf` then you are probably using an old version of the BlueField image. Check the way of enabling IPsec full offload in a previous DOCA versions in the [NVIDIA DOCA Documentation Archives](#).

2. Restart IB driver (rebooting also works). Run:

```
/etc/init.d/openibd restart
```

Note

If `mlx-regex` is running:

1. Disable `mlx-regex` prior to running restarting the IB driver:

```
systemctl stop mlx-regex
```

2. Restart IB driver according to the command above.
3. Re-enable `mlx-regex` after the restart has finished:

```
systemctl restart mlx-regex
```

(i) Note

To revert IPsec full offload mode, redo the procedure from step 1, only difference is to set `IPSEC_FULL_OFFLOAD="no"` in `/etc/mellanox/mlnx-bf.conf`.

5.2 Configuring OVS IPsec

(i) Note

Before proceeding with this section, make sure to follow the procedure in section "[Enabling IPsec Packet Offload](#)" for both DPUs.

This section configures OVS IPsec VXLAN tunnel which automatically generates the `swanctl.conf` files and runs strongSwan (the IPsec daemon). The following figure illustrates an example with two BlueField DPUs, Left and Right, operating with a secured VXLAN channel.

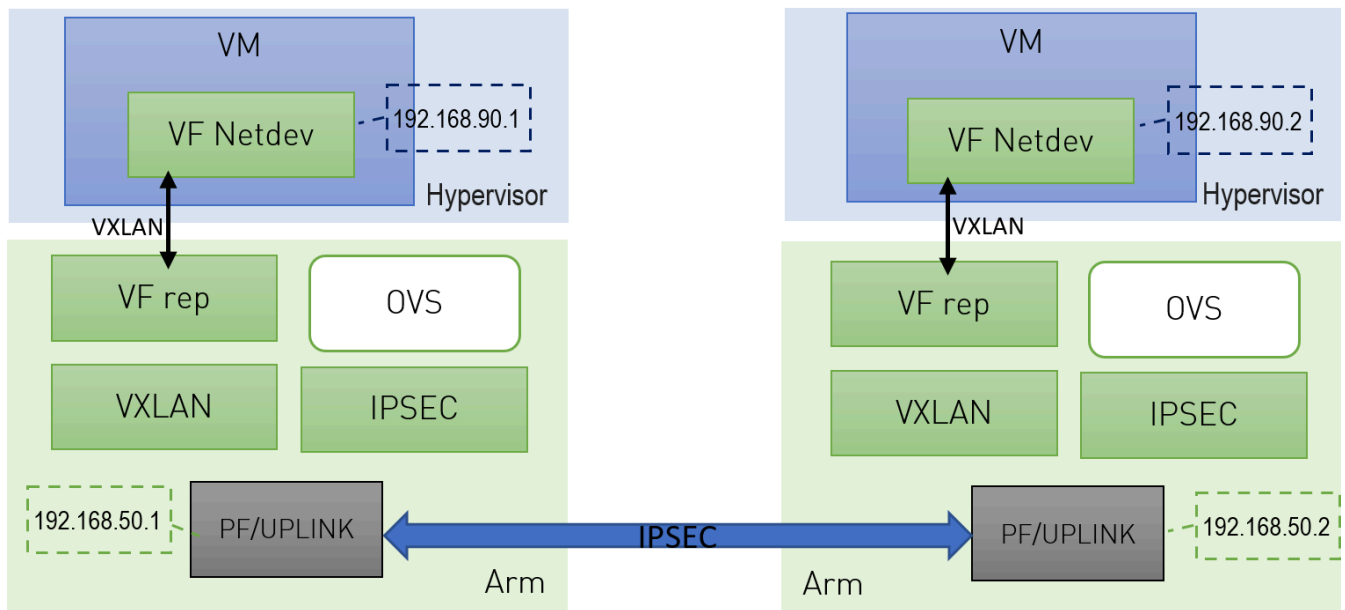

Two BlueField DPUs are required to build an OVS IPsec tunnel between the two hosts, Right and Left.

The OVS IPsec tunnel configures an unaware IPsec connection between the two hosts' InfiniBand devices. For the sake of this example, the host's InfiniBand network device is `HOST_PF`, and the DPU's host representor is `PF_REP` and the DPU's physical function `PF`.

This example sets up the following variables on both Arms:

```
# host_ip1=1.1.1.1
# host_ip2=1.1.1.2
# HOST_PF=ens7np0
# ip1=192.168.50.1
# ip2=192.168.50.2
# PF=p0
# PF_REP=pf0hpf
```

Note

The name of the `HOST_PF` could be different in your machine. You may verify this by running:

```
host# ibdev2netdev
mlx5_0 port 1 ==> ens7np0 (Down)
mlx5_1 port 1 ==> ens8np1 (Down)
```

This example uses the first InfiniBand's (`mlx5_0`) network device which is `ens7np0`.

1. Configure IP addresses for the `HOST_PF`s of both hosts (x86):

1. On `host_1`:

```
# ifconfig $HOST_PF $host_ip1/24 up
```

2. On `host_2`:

```
# ifconfig $HOST_PF $host_ip2/24 up
```

Note

Step 1 is the only command that is performed on the host, the rest of the commands are performed on the Arm (DPU) side.

2. Configure IP addresses for the PFs of both Arms:

1. On `Arm_1`:

```
# ifconfig $PF $ip1/24 up
```

2. On `Arm_2`:

```
# ifconfig $PF $ip2/24 up
```

3. Start Open vSwitch. If your operating system is Ubuntu, run the following on both `Arm_1` and `Arm_2`:

```
# service openvswitch-switch start
```

If your operating system is CentOS, run the following on both `Arm_1` and `Arm_2`:

```
# service openvswitch restart
```

4. Start OVS IPsec service. Run on both `Arm_1` and `Arm_2`:

```
# systemctl start openvswitch-ipsec.service
```

5. Set up OVS bridges in both DPUs. Run on both `Arm_1` and `Arm_2`:

```
# ovs-vsctl add-br vxlan-br  
# ovs-vsctl add-port ovs-br $PF_REP  
# ovs-vsctl set Open_vSwitch . other_config:hw-offload=true
```

(i) Note

Configuring `other_config:hw-offload=true` sets IPsec Packet offload. Setting it to `false` sets software IPsec.

(i) Note

The MTU of the MTU of the tunnel interface (PF) should be at least 50 bytes larger than the MTU of the endpoints of the tunnels above (PF_REP) to account for the size of the VXLAN tunnel header. For example, if the MTU of PF_REP is 1500 then the MTU of PF should be at least 1550.

To configure the MTU of the PF:

```
# ifconfig $PF mtu $PF_MTU up
```

6. Set up IPsec tunnel on the OVS bridge. Three authentication methods are possible, choose your preferred authentication method and follow the steps relevant to it. Note that the last two authentication methods requires you to create certificates (self-signed certificates or certificate authority certificates).

(i) Note

After the IPsec tunnel is set up using one of the three methods of authentication, strongSwan configuration is done automatically and the `swanctl.conf` files will be generated and strongSwan will run automatically.

5.2.1 Authentication Methods

The following subsections detail the possible authentication methods for setting up the IPsec tunnel on the OVS bridge.

Pre-shared Key

This method configures OVS IPsec using a pre-shared key. You must select a pre-shared key, for example:

```
psk=swordfish
```

1. Set up the VXLAN tunnel:

1. On `Arm_1`, run:

```
# ovs-vsctl add-port vxlan-br tun -- \  
    set interface tun type=vxlan \  
        options:local_ip=$ip1 \  
        options:remote_ip=$ip2 \  
        options:key=100 \  
        options:dst_port=4789 \  
        options:psk=$psk
```

2. On `Arm_2`, run:

```
# ovs-vsctl add-port vxlan-br tun -- \  
    set interface tun type=vxlan \  
        options:local_ip=$ip2 \  
        options:remote_ip=$ip1 \  
        options:key=100 \  
        options:dst_port=4789 \  
        options:psk=$psk
```

Self-signed Certificate

This method configures OVS IPsec using self-signed certificates. You must generate self-signed certificates and keys. This example demonstrates how to generate self-signed certificates using `ovs-pki` but you may generate them in any other way while skipping step 1.

1. Generate self-signed certificates using `ovs-pki`:

1. On `Arm_1`, run:

```
# ovs-pki req -u host_1
# ovs-pki self-sign host_1
```

After running this code you should have `host_1-cert.pem` and `host_1-privkey.pem`.

2. On `Arm_2`, run:

```
# ovs-pki req -u host_2
# ovs-pki self-sign host_2
```

After running this code you should have `host_2-cert.pem` and `host_2-privkey.pem`.

2. Configure the certificates and private keys:

1. Copy the certificate of `Arm_1` to `Arm_2`, and the certificate of `Arm_2` to `Arm_1`.
2. On each machine, move both `host_1-privkey.pem` and `host_2-cert.pem` to `/etc/swanctl/x509/` if on Ubuntu, or `/etc/strongswan/swanctl/x509/` if on CentOS.

3. On each machine, move the local private key (`host_1-privkey.pem` on `Arm_1` and `host_2-privkey.pem` on `Arm_2`) to `/etc/swanctl/private` if on Ubuntu, or `/etc/strongswan/swanctl/private` if on CentOS.

3. Set up OVS `other_config` on both sides.

1. On `Arm_1`:

```
# ovs-vsctl set Open_vSwitch .
other_config:certificate=/etc/swanctl/x509/host_1-
cert.pem \
    other_config:private_key=/etc/swanctl/private/host_1-
privkey.pem
```

2. On `Arm_2`:

```
# ovs-vsctl set Open_vSwitch .
other_config:certificate=/etc/swanctl/x509/host_2-
cert.pem \
    other_config:private_key=/etc/swanctl/private/host_2-
privkey.pem
```

4. Set up the VXLAN tunnel:

1. On `Arm_1`:

```
# ovs-vsctl add-port vxlan-br vxlanp0 -- set interface
vxlanp0 type=vxlan options:local_ip=$ip1 \
    options:remote_ip=$ip2 options:key=100
options:dst_port=4789 \
    options:remote_cert=/etc/swanctl/x509/host_2-cert.pem
```

```
# service openvswitch-switch restart
```

2. On `Arm_2`:

```
# ovs-vsctl add-port vxlan-br vxlanp0 -- set interface  
vxlanp0 type=vxlan options:local_ip=$ip2 \  
options:remote_ip=$ip1 options:key=100  
options:dst_port=4789 \  
options:remote_cert=/etc/swanctl/x509/host_1-cert.pem  
# service openvswitch-switch restart
```

i Note

In steps 3 and 4, if you are in CentOS you must change the path of the certificates to `/etc/strongswan/swanctl/x509/` and the path of the private keys to `/etc/strongswan/swanctl/private`.

CA-signed Certificate

This method configures OVS IPsec using certificate authority (CA)-signed certificates. You must generate CA-signed certificates and keys. The example demonstrates how to generate CA-signed certificates using `ovs-pki` but you may generate them in any other way while skipping step 1.

1. Generate CA-signed certificates using `ovs-pki`. For this method, all the certificates and the requests must be in the same directory during the certificate generating and signing. This example refers to this directory as `certsworkspace`.

1. On `Arm_1`, run:

```
# ovs-pki init --force
# cp /var/lib/openswitch/pki/controllerca/cacert.pem
<path_to>/certsworkspace
# cd <path_to>/certsworkspace
# ovs-pki req -u host_1
# ovs-pki sign host1 switch
```

After running this code, you should have `host_1-cert.pem`, `host_1-privkey.pem`, and `cacert.pem` in the `certsworkspace` folder.

2. On `Arm_2`, run:

```
# ovs-pki init --force
# cp /var/lib/openswitch/pki/controllerca/cacert.pem
<path_to>/certsworkspace
# cd <path_to>/certsworkspace
# ovs-pki req -u host_2
# ovs-pki sign host_2 switch
```

After running this code, you should have `host_2-cert.pem`, `host_2-privkey.pem`, and `cacert.pem` in the `certsworkspace` folder.

2. Configure the certificates and private keys:

1. Copy the certificate of `Arm_1` to `Arm_2` and the certificate of `Arm_2` to `Arm_1`.
2. On each machine, move both `host_1-privkey.pem` and `host_2-cert.pem` to `/etc/swanctl/x509/` if on Ubuntu, or `/etc/strongswan/swanctl/x509/` if on CentOS.
3. On each machine, move the local private key (`host_1-privkey.pem` if on `Arm_1` and `host_2-privkey.pem` if on `Arm_2`) to

`/etc/swanctl/private` if on Ubuntu, or
`/etc/strongswan/swanctl/private` if on CentOS.

4. On each machine, copy `cacert.pem` to the `x509ca` directory under
`/etc/swanctl/x509ca/` if on Ubuntu, or
`/etc/strongswan/swanctl/x509ca/` if on CentOS.

3. Set up OVS `other_config` on both sides.

1. On `Arm_1`:

```
# ovs-vsctl set Open_vSwitch . \  
other_config:certificate=/etc/strongswan/swanctl/x509/host \  
\  
other_config:private_key=/etc/strongswan/swanctl/private/h \  
privkey.pem \  
\  
other_config:ca_cert=/etc/strongswan/swanctl/x509ca/cacert
```

2. On `Arm_2`:

```
# ovs-vsctl set Open_vSwitch . \  
other_config:certificate=/etc/strongswan/swanctl/x509/host \  
\  
other_config:private_key=/etc/strongswan/swanctl/private/h \  
privkey.pem \  
\  
other_config:ca_cert=/etc/strongswan/swanctl/x509ca/cacert
```

4. Set up the tunnel:

1. On `Arm_1`:

```
# ovs-vsctl add-port vxlan-br vxlanp0 -- set interface
vxlanp0 type=vxlan options:local_ip=$ip1 \
options:remote_ip=$ip2 options:key=100
options:dst_port=4789 \ options:remote_name=host_2
# service openvswitch-switch restart
```

2. On `Arm_2`:

```
# ovs-vsctl add-port vxlan-br vxlanp0 -- set interface
vxlanp0 type=vxlan options:local_ip=$ip2 \
options:remote_ip=$ip1 options:key=100
options:dst_port=4789 \ options:remote_name=host_1
# service openvswitch-switch restart
```

Note

In steps 3 and 4, if you are in CentOS you must change the path of the certificates to `/etc/strongswan/swanctl/x509/`, the path of the CA certificate to `/etc/strongswan/swanctl/x509ca/`, and the path of the private keys to `/etc/strongswan/swanctl/private/`.

5.3 Ensuring IPsec is Configured

Using `/opt/mellanox/iproute2/sbin/ip xfrm state show`, you should be able to see 4 IPsec states for the IPsec connection you configured with the keyword `in mode packet` meaning which means that you are in IPsec packet HW offload mode.

For example, after configuring IPsec using pre-shared key method, you would get something similar to the following on `Arm_1`:

```
# /opt/mellanox/iproute2/sbin/ip xfrm state show

src 192.168.50.1 dst 192.168.50.2
    proto esp spi 0xcc8bf8ad reqid 1 mode transport
    replay-window 0 flag esn
    aead rfc4106(gcm(aes))
0x9f45cc4577e70c4e077bcc0c1473a782143e7ad199f58566519639d03b593b8996383f11 128
    anti-replay esn context:
        seq-hi 0x0, seq 0x0, oseq-hi 0x0, oseq 0x0
        replay_window 1, bitmap-length 1
        00000000
    crypto offload parameters: dev p0 dir out mode packet
    sel src 192.168.50.1/32 dst 192.168.50.2/32 proto udp sport 4789

src 192.168.50.2 dst 192.168.50.1
    proto esp spi 0xce8bf4b6 reqid 1 mode transport
    replay-window 0 flag esn
    aead rfc4106(gcm(aes))
0xf2d0e335d9a64ef6e385a630a32b0e43bb52f581290cd34bbb8f7592d54f11657ed0258e 128
    anti-replay esn context:
        seq-hi 0x0, seq 0x0, oseq-hi 0x0, oseq 0x0
        replay_window 32, bitmap-length 1
        00000000
    crypto offload parameters: dev p0 dir in mode packet
    sel src 192.168.50.2/32 dst 192.168.50.1/32 proto udp dport 4789

src 192.168.50.1 dst 192.168.50.2
    proto esp spi 0xcb600a84 reqid 2 mode transport
    replay-window 0 flag esn
```

```

    aead rfc4106(gcm(aes))
0x7fb26035299bcc9b973abea5d581acfbcf87cbf0bd053b745c4d95c62311f934010973f6 128
    anti-replay esn context:
      seq-hi 0x0, seq 0x0, oseq-hi 0x0, oseq 0x0
      replay_window 1, bitmap-length 1
      00000000
    crypto offload parameters: dev p0 dir out mode packet
    sel src 192.168.50.1/32 dst 192.168.50.2/32 proto udp dport 4789
src 192.168.50.2 dst 192.168.50.1
    proto esp spi 0xc137d5a0 reqid 2 mode transport
    replay-window 0 flag esn
    aead rfc4106(gcm(aes))
0x28e3d12ad4e24aa9d9de9459de8ef8bb4379e8e12faac0054c5b629b6aa50fdeda8e4574 128
    anti-replay esn context:
      seq-hi 0x0, seq 0x0, oseq-hi 0x0, oseq 0x0
      replay_window 32, bitmap-length 1
      00000000
    crypto offload parameters: dev p0 dir in mode packet
    sel src 192.168.50.2/32 dst 192.168.50.1/32 proto udp sport 4789

```

After insuring that the IPsec connection is configured, you can send encrypted traffic between `host_1` and `host_2` using the `HOST_PF`'s IP addresses.

5.4 Configuring OVS IPsec Using strongSwan Manually

This section configures an OVS VXLAN tunnel which then uses `swanctl.conf` files and runs strongSwan (the IPsec daemon) manually.

Note

Before proceeding with this section, make sure to follow the procedure in section "[Enabling IPsec Packet Offload](#)" for both DPUs.

1. Build a VXLAN tunnel over OVS and connect the PF representor to the same OVS bridge.

1. On `Arm_1`:

```
# ovs-vsctl add-br vxlan-br
# ovs-vsctl add-port vxlan-br PF_REP
# ovs-vsctl add-port vxlan-br vxlan11 -- set interface
vxlan11 type=vxlan options:local_ip=$ip1 \
        options:remote_ip=$ip2 options:key=100
options:dst_port=4789 \
# ovs-vsctl set Open_vSwitch . other_config:hw-
offload=true
```

2. On `Arm_2`:

```
# ovs-vsctl add-br vxlan-br
# ovs-vsctl add-port vxlan-br PF_REP
# ovs-vsctl add-port vxlan-br vxlan11 -- set interface
vxlan11 type=vxlan options:local_ip=$ip2 \
        options:remote_ip=$ip1 options:key=100
options:dst_port=4789 \
# ovs-vsctl set Open_vSwitch . other_config:hw-
offload=true
```

2. If your operating system is Ubuntu, run on both `Arm_1` and `Arm_2`:

```
service openvswitch-switch start
```

If your operating system is CentOS, run:

```
service openvswitch restart
```

3. Enable TC offloading for the PF. Run on both `Arm_1` and `Arm_2`:

```
# ethtool -K $PF hw-tc-offload on
```

4. Disable host PF as the port owner from Arm. Run on both `Arm_1` and `Arm_2`:

```
# mlxprivhost -d /dev/mst/mt${pciconf} --disable_port_owner r
```

Note

To get `${pciconf}`, run the following on the DPU:

```
# ls --color=never /dev/mst/ | grep --  
color=never '^m.*f0$' | cut -c 3-
```

For example:

```
# mlxprivhost -d /dev/mst/mt41686_pciconf0 --  
disable_port_owner r
```

5. Configure the `swanctl.conf` files for each machine. See section [swanctl.conf Files](#).

(i) Note

Each machine should have exactly one `.swanctl.conf` file in `/etc/swanctl/conf.d/`.

6. Load the `swanctl.conf` files and initialize strongSwan. Run:

1. On the `Arm_2`, run:

```
systemctl restart strongswan.service
swanctl --load-all
```

2. On the `Arm_1`, run:

```
systemctl restart strongswan.service
swanctl --load-all
swanctl -i --child bf
```

Now the IPsec connection should be established.

5.5 swanctl.conf Files

strongSwan configures IPsec packet HW offload using a new value added to its configuration file `swanctl.conf`. The file should be placed under `sysconfdir` which by default can be found at `/etc/swanctl/swanctl.conf`.

The terms Left (BFL) and Right (BFR), in reference to the illustration under "[Application Architecture](#)", are used to identify the two nodes (or machines) that communicate.

i Note

Either side (BFL or BFR) can fulfill either role (initiator or receiver).

In this example, 192.168.50.1 is used for the left PF uplink and 192.168.50.2 for the right PF uplink.

```
connections {
  BFL-BFR {
    local_addrs = 192.168.50.1
    remote_addrs = 192.168.50.2

    local {
      auth = psk
      id = host1
    }
    remote {
      auth = psk
      id = host2
    }

    children {
      bf-out {
        local_ts = 192.168.50.1/24 [udp]
        remote_ts = 192.168.50.2/24 [udp/4789]
        esp_proposals = aes128gcm128-x25519-esn
        mode = transport
        policies_fwd_out = yes
        hw_offload = packet
      }
      bf-in {
        local_ts = 192.168.50.1/24 [udp/4789]
        remote_ts = 192.168.50.2/24 [udp]
        esp_proposals = aes128gcm128-x25519-esn
      }
    }
  }
}
```

```

        mode = transport
        policies_fwd_out = yes
        hw_offload = packet
    }
}
version = 2
mobike = no
reauth_time = 0
proposals = aes128-sha256-x25519
}
}

secrets {
    ike-BF {
        id-host1 = host1
        id-host2 = host2
        secret = 0sv+NkxY9LLZvwj4qCC2o/gGrWDF2d21jL
    }
}

```

The BFB installation will place two example `swanctl.conf` files for BFL and BFR (`BFL.swanctl.conf` and `BFR.swanctl.conf` respectively) in the `strongSwan.conf.d` directory. Each node should have only one `swanctl.conf` file in its `strongSwan.conf.d` directory.

Note that:

- "`hw_offload = packet`" is responsible for configuring IPsec packet offload
- Packet offload support has been added to the existing `hw_offload` field and preserves backward compatibility.

For your reference:

Value	Description
no	Do not configure HW offload.

Value	Description
crypto	Configure crypto HW offload if supported by the kernel and hardware, fail if not supported.
yes	Same as crypto (considered legacy).
packet	Configure packet HW offload if supported by the kernel and hardware, fail if not supported.
auto	Configure packet HW offload if supported by the kernel and hardware, do not fail (perform fallback to crypto or no as necessary).

- Whenever the value of `hw_offload` is changed, strongSwan configuration must be reloaded.
- Switching to crypto HW offload requires setting up `devlink/ipsec_mode` to `none` beforehand.
- Switching to packet HW offload requires setting up
- `[udp/4789]` is crucial for instructing strongSwan to IPsec only VXLAN communication.
- Packet HW offload can only be done on what is streamed over VXLAN.

Mind the following limitations:

Fields	Limitation
reauth_time	Ignored if set
rekey_time	Do not use. Ignored if set.
rekey_bytes	Do not use. Not supported and will fail if it is set.
rekey_packets	Use for rekeying

6. Running the Application

6.1 Installation

Please refer to the [NVIDIA DOCA Installation Guide for Linux](#) for details on how to install BlueField-related software.

6.2 Application Execution

Notes:

- IPsec daemons are started by `systemd strongswan.service`
- Use `systemctl [start | stop | restart]` to control IPsec daemons through `strongswan.service`. For example, to restart, run:

```
systemctl restart strongswan.service
```

This command effectively does the same thing as `ipsec restart`.

Note

Do not use the `ipsec` script (located under `/usr/sbin/ipsec`) to restart/stop/start the IPsec connection.

This subsection explains how to configure and set an IPsec connection using the script. To configure the IPsec connection, you need two DPUs, referred to as the initiator and receiver machines. There are no differences between the two machines except that the initiator is the one that initiates the connection between the two (and should run the script after the receiver).

The script is located under

```
/opt/mellanox/doca/applications/east_west_overlay_encryption/east_wes
```

6.2.1 Script Parameters

Parameter	Description	Valid Values
<code>side</code>	The side of the	<ul style="list-style-type: none">• <code>r receiver</code>

Parameter	Description	Valid Values
	connection (receiver or initiator).	<ul style="list-style-type: none"> <code>i initiator</code>
<code>j json</code>	The JSON parameters file full path.	JSON file path, written according to the terminology: <code>/opt/mellanox/doca/applications/e</code>
<code>initiator_ip_addr</code>	The IP address of the initiator machine's port interface for the IPsec connection.	A valid IP address, ranging from 1.1.1.1 to 2
<code>receiver_ip_addr</code>	The IP address of the receiver machine's port interface for the IPsec connection.	A valid IP address, ranging from 1.1.1.1 to 2
<code>port_num</code>	The number of the port interface (p0/p1) for the IPsec connection.	0 or 1.
<code>auth_method</code>	the authentication method of IPsec. can be <code>psk</code> (pre-shared key), <code>ssc</code> (self-signed certificate) or <code>ca</code> (CA-signed	Can be <code>psk</code> (pre-shared key), <code>ssc</code> (self-si

Parameter	Description	Valid Values
	certificate). Set by default to <code>psk</code> .	
<code>preshared_key</code>	The pre-shared key.	A sequence of characters (string).
<code>initiator_cert_path</code>	The initiator's certificate.	Any valid self-signed or CA signed certificate
<code>receiver_cert_path</code>	The receiver's certificate.	Any valid self-signed or CA signed certificate
<code>initiator_key_path</code>	the initiator's private-key.	Any valid private key that is generated with
<code>receiver_key_path</code>	the receiver's private-key.	Any valid private key that is generated with

Parameter	Description	Valid Values
<code>initiator_cacert_path</code>	The initiator's CA certificate.	Any valid CA certificate. Must provide full pa
<code>receiver_cacert_path</code>	The receiver's CA certificate.	Any valid CA certificate. Must provide full pa
<code>initiator_cn</code>	The common name (CN) of the initiator's certificate.	Must be the same as the CN described in th
<code>receiver_cn</code>	The CN of the receiver's certificate.	Must be the same as the CN described in th

There are two ways of passing the parameters, either [using the JSON parameters file](#) or by [passing the parameters on the command line](#).

6.2.2 Using JSON Parameters File

In this method, you must configure the parameters file and then run the script:

1. Configure the JSON parameters file located under `/opt/mellanox/doca/applications/east_west_overlay_encryption/east_west_overlay_encryption_params.json` or create a JSON file according to the template of `east_west_overlay_encryption_params.json` for the script according to the explanation under section "[Script Parameters](#)".
2. Run the script on the receiver's DPU with the JSON file:

```
/opt/mellanox/doca/applications/east_west_overlay_encryption/e
--side=r --
json=/opt/mellanox/doca/applications/east_west_overlay_encrypt
```

3. Run the script on the initiator's DPU:

```
/opt/mellanox/doca/applications/east_west_overlay_encryption/e
--side=i --
json=/opt/mellanox/doca/applications/east_west_overlay_encrypt
```

You may now send encrypted data over the PF interface (192.168.50.[1|2]) configured for VXLAN.

6.2.3 Passing Parameters on Command Line

In this method, you do not need to configure the parameters file and can run the script with the [appropriate parameters](#).

Passing Parameters for Pre-shared Key Authentication Method

1. Run the script on the receiver's DPU:

```
/opt/mellanox/doca/applications/east_west_overlay_encryption/e
--side=r --initiator_ip_addr=INITIATOR_IP_ADDRESS --
receiver_ip_addr=RECEIVER_IP_ADDRESS --port_num=PORT_NUM \
```

```
--auth_method=psk --preshared_key=PRESHARED_KEY
```

2. Run the script on the initiator's DPU:

```
/opt/mellanox/doca/applications/east_west_overlay_encryption/e  
--side=i --initiator_ip_addr=INITIATOR_IP_ADDRESS --  
receiver_ip_addr=RECEIVER_IP_ADDRESS --port_num=PORT_NUM \  
--auth_method=psk --preshared_key=PRESHARED_KEY
```

Passing Parameters for Self-signed Certificates Authentication Method

1. Run the script on the receiver's DPU:

```
/opt/mellanox/doca/applications/east_west_overlay_encryption/e  
--side=r --initiator_ip_addr=INITIATOR_IP_ADDRESS --  
receiver_ip_addr=RECEIVER_IP_ADDRESS --port_num=PORT_NUM \  
--auth_method=ssc --initiator_cert_path=INITIATOR_CERT_PATH -  
-receiver_cert_path=RECEIVER_CERT_PATH --  
receiver_key_path=RECEIVER_KEY_PATH
```

2. Run the script on the initiator's DPU:

```
/opt/mellanox/doca/applications/east_west_overlay_encryption/e  
--side=i --initiator_ip_addr=INITIATOR_IP_ADDRESS --  
receiver_ip_addr=RECEIVER_IP_ADDRESS --port_num=PORT_NUM \  
--auth_method=ssc --initiator_cert_path=INITIATOR_CERT_PATH -  
-receiver_cert_path=RECEIVER_CERT_PATH --  
initiator_key_path=INITIATOR_KEY_PATH
```

Passing Parameters for CA Certificates Authentication Method

1. Run the script on the receiver's DPU:

```
/opt/mellanox/doca/applications/east_west_overlay_encryption/e
--side=r --initiator_ip_addr=INITIATOR_IP_ADDRESS --
receiver_ip_addr=RECEIVER_IP_ADDRESS --port_num=PORT_NUM \
--auth_method=ca --initiator_cert_path=INITIATOR_CERT_PATH --
receiver_cert_path=RECEIVER_CERT_PATH --
receiver_key_path=RECEIVER_KEY_PATH --
receiver_cacert_path=RECEIVER_CACERT_PATH --
initiator_cn=INITIATOR_CN
```

2. Run the script on the initiator's DPU:

```
/opt/mellanox/doca/applications/east_west_overlay_encryption/e
--side=i --initiator_ip_addr=INITIATOR_IP_ADDRESS --
receiver_ip_addr=RECEIVER_IP_ADDRESS --port_num=PORT_NUM \
--auth_method=ssc --initiator_cert_path=INITIATOR_CERT_PATH -
-receiver_cert_path=RECEIVER_CERT_PATH --
initiator_key_path=INITIATOR_KEY_PATH --
initiator_cacert_path=INITIATOR_CACERT_PATH --
receiver_cn=RECEIVER_CN
```

For help and usage, run the script with `--help`/`-h` flag:

```
/opt/mellanox/doca/applications/east_west_overlay_encryption/east_w
-h
```

6.3 Troubleshooting

Please refer to the [NVIDIA DOCA Troubleshooting Guide](#) for any issue you may encounter with the installation or execution of the DOCA applications.

6.4 Building strongSwan

Note

Perform the following only if you want to build your own BFB and would like to rebuild strongSwan.

1. Install dependencies mentioned [here](#). libgmp-dev is missing from that list, so make sure to install that as well.
2. Git clone <https://github.com/Mellanox/strongswan.git>.
3. Git checkout BF-5.9.10. This branch is based on the official strongSwan 5.9.10 branch (<https://github.com/strongswan/strongswan/tree/5.9.10>) with added packaging and support for DOCA IPsec plugin (check [NVIDIA DOCA IPsec Security Gateway Application Guide](#) for more information regarding strongSwan DOCA plugin).
4. Run autogen.sh within the strongSwan repo.
5. Run the following:

```
configure --enable-openssl --disable-random --  
prefix=/usr/local --sysconfdir=/etc --enable-systemd  
make  
make install
```

Notes:

- `--enable-systemd` enables the systemd service for strongSwan present inside the GitHub repo (see step 3) at `init/systemd-starter/strongswan.service.in`.
- When building strongSwan on your own, the `openssl.cnf.mlnx` file, required for PK and RNG HW offload via OpenSSL plugin, is not installed. It must be copied over manually from GitHub repo inside the `openssl-conf` directory. See section "[Running Strongswan Example](#)" for important notes.
- The `openssl.cnf.mlnx` file references PKA engine shared objects. libpka (version 1.3 or later) and openssl (version 1.1.1) must be installed for this to work.

6.5 Reverting IPsec Configuration

To destroy IPsec configuration, run the following on both machines:

```
/opt/mellanox/doca/applications/east_west_overlay_encryption/east_west_overlay_encryption -d
```

Note

Make sure to run this command only after at least two minutes have passed from running the application on either machines. Otherwise, this may lead to errors.

Note

If you run this command without initializing the connection first (in [Running strongSwan Example](#)), you may receive errors. These errors have no functional impact and may be safely ignored.

7. References

-

- `/opt/mellanox/doca/applications/east_west_overlay_encryption/`
- `/opt/mellanox/doca/applications/east_west_overlay_encryption/`

Notice

This document is provided for information purposes only and shall not be regarded as a warranty of a certain functionality, condition, or quality of a product. NVIDIA Corporation ("NVIDIA") makes no representations or warranties, expressed or implied, as to the accuracy or completeness of the information contained in this document and assumes no responsibility for any errors contained herein. NVIDIA shall have no liability for the consequences or use of such information or for any infringement of patents or other rights of third parties that may result from its use. This document is not a commitment to develop, release, or deliver any Material (defined below), code, or functionality.

NVIDIA reserves the right to make corrections, modifications, enhancements, improvements, and any other changes to this document, at any time without notice.

Customer should obtain the latest relevant information before placing orders and should verify that such information is current and complete.

NVIDIA products are sold subject to the NVIDIA standard terms and conditions of sale supplied at the time of order acknowledgement, unless otherwise agreed in an individual sales agreement signed by authorized representatives of NVIDIA and customer ("Terms of Sale"). NVIDIA hereby expressly objects to applying any customer general terms and conditions with regards to the purchase of the NVIDIA product referenced in this document. No contractual obligations are formed either directly or indirectly by this document.

NVIDIA products are not designed, authorized, or warranted to be suitable for use in medical, military, aircraft, space, or life support equipment, nor in applications where failure or malfunction of the NVIDIA product can reasonably be expected to result in personal injury, death, or property or environmental damage. NVIDIA accepts no liability for inclusion and/or use of NVIDIA products in such equipment or applications and therefore such inclusion and/or use is at customer's own risk.

NVIDIA makes no representation or warranty that products based on this document will be suitable for any specified use. Testing of all parameters of each product is not necessarily performed by NVIDIA. It is customer's sole responsibility to evaluate and determine the applicability of any information contained in this document, ensure the product is suitable and fit for the application planned by customer, and perform the necessary testing for the application in order to avoid a default of the application or the product. Weaknesses in customer's product designs may affect the quality and reliability of the NVIDIA product and may result in additional or different conditions and/or requirements beyond those contained in this document. NVIDIA accepts no liability related to any default, damage, costs, or problem which may be based on or attributable to: (i) the use of the NVIDIA product in any manner that is contrary to this document or

(ii) customer product designs.

No license, either expressed or implied, is granted under any NVIDIA patent right, copyright, or other NVIDIA intellectual property right under this document. Information published by NVIDIA regarding third-party products or services does not constitute a license from NVIDIA to use such products or services or a warranty or endorsement thereof. Use of such information may require a license from a third party under the patents or other intellectual property rights of the third party, or a license from NVIDIA under the patents or other intellectual property rights of NVIDIA.

Reproduction of information in this document is permissible only if approved in advance by NVIDIA in writing, reproduced without alteration and in full compliance with all applicable export laws and regulations, and accompanied by all associated conditions, limitations, and notices.

THIS DOCUMENT AND ALL NVIDIA DESIGN SPECIFICATIONS, REFERENCE BOARDS, FILES, DRAWINGS, DIAGNOSTICS, LISTS, AND OTHER DOCUMENTS (TOGETHER AND SEPARATELY, "MATERIALS") ARE BEING PROVIDED "AS IS." NVIDIA MAKES NO WARRANTIES, EXPRESSED, IMPLIED, STATUTORY, OR OTHERWISE WITH RESPECT TO THE MATERIALS, AND EXPRESSLY DISCLAIMS ALL IMPLIED WARRANTIES OF NONINFRINGEMENT, MERCHANTABILITY, AND FITNESS FOR A PARTICULAR PURPOSE. TO THE EXTENT NOT PROHIBITED BY LAW, IN NO EVENT WILL NVIDIA BE LIABLE FOR ANY DAMAGES, INCLUDING WITHOUT LIMITATION ANY DIRECT, INDIRECT, SPECIAL, INCIDENTAL, PUNITIVE, OR CONSEQUENTIAL DAMAGES, HOWEVER CAUSED AND REGARDLESS OF THE THEORY OF LIABILITY, ARISING OUT OF ANY USE OF THIS DOCUMENT, EVEN IF NVIDIA HAS BEEN ADVISED OF THE POSSIBILITY OF SUCH DAMAGES. Notwithstanding any damages that customer might incur for any reason whatsoever, NVIDIA's aggregate and cumulative liability towards customer for the products described herein shall be limited in accordance with the Terms of Sale for the product.

Trademarks

NVIDIA and the NVIDIA logo are trademarks and/or registered trademarks of NVIDIA Corporation in the U.S. and other countries. Other company and product names may be trademarks of the respective companies with which they are associated.

© Copyright 2025, NVIDIA. PDF Generated on 10/09/2025