



MMA1B00-C100D 100GbE QSFP28 MMF SR4 Transceiver Product Specifications

Table of Contents

Introduction.....	3
Key Features.....	3
Applications.....	3
Pin Description	4
QSFP28 Pin Function Description	4
QSFP28 Module Pad Layout.....	5
Control Signals	5
Diagnostics and Other Features.....	6
Specifications.....	7
Absolute Maximum Specifications	7
Recommended Operating Conditions and Power Supply Requirements	7
Electrical Specifications	7
Optical Specifications	8
Electrostatic Discharge (ESD)	9
Handling and Cleaning	9
Mechanical Specifications	10
Memory Map	11
Label.....	11
Backshell Label Legend	11
Regulatory Compliance and Classification	12
FCC Class A Notice	12
Ordering Information.....	14
References	15
Appendix: Optical Connector and Patch Cable.....	16
Optical Connector	16
Patch Cable	16
Document Revision History	18

Introduction

NVIDIA® MMA1B00-C100D is a 4-channel, pluggable QSFP28 optical transceiver designed for use in 100GbE Ethernet links with up to 100 m reach on multi-mode fiber (MMF). This transceiver incorporates our integrated circuit technology to provide high performance at low power.

The MMA1B00-C100D converts 4 input channels of 25 Gb/s electrical data to 4 optical signals at 850 nm. Reversely, the receiver side demultiplexes 4 optical inputs into 4 electrical differential output signals.

The transceiver has selectable retiming as specified in the SFF-8636 MSA. The transceiver can therefore be used in both 40 GbE and 100 GbE applications.

Digital diagnostic monitoring functions for temperature, supply voltage, and optical power are available via the two-wire (I2C) management interface, as specified by the QSFP28 MSA.

The optical interface is a Multi-fiber Push-On (MPO) connector with four optical channels/fibers in each direction. The MPO connector is un-angled (UPC).

Rigorous production testing ensures the best out-of-the-box installation experience, performance, and durability.

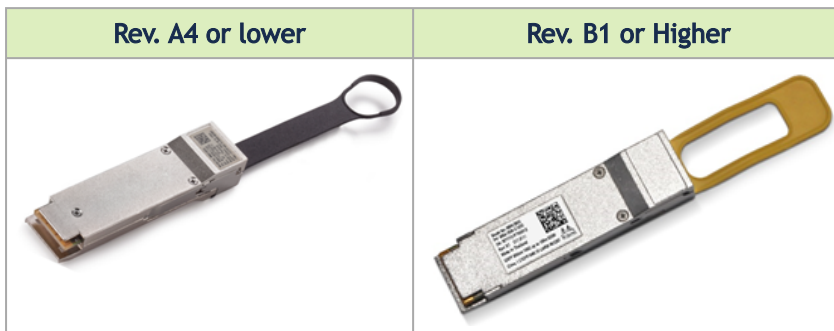

 Images are for illustration purposes only. Product labels, colors, and lengths may vary.

Key Features

- Up to 100Gb/s
- Selectable retiming for both Tx and Rx
- Programmable Tx input equalizer
- Programmable Rx output amplitude and emphasis
- SFF-8665 compliant QSFP28
- Single 3.3V supply, hot pluggable
- QSFP28 power class 3 (2.5 W max)
- 2.2 W power consumption (typ, with retiming)
- Class 1 laser safety
- Up to 100m on OM4, and 70m on OM3 multimode fiber at 100 Gb/s
- Up to 100m on OM3 at 40 Gb/s
- SFF-8636 compliant DDM
- Hot pluggable
- RoHS compliant

Applications

- 100GBASE-SR4 100G Ethernet
- 40GBASE-SR4 40G Ethernet
- Qualified for use in NVIDIA Ethernet end-to-end systems

Pin Description

QSFP28 Pin Function Description

The transceiver's pin assignment is SFF-8679 compliant.

Pin	Symbol	Description	Pin	Symbol	Description
1	GND	Ground	20	GND	Ground
2	Tx2n	Transmitter Inverted Data Input	21	Rx2n	Receiver Inverted Data Output
3	Tx2p	Transmitter Non-Inverted Data Input	22	Rx2p	Receiver Non-Inverted Data Output
4	GND	Ground	23	GND	Grounds
5	Tx4n	Transmitter Inverted Data Input	24	Rx4n	Receiver Inverted Data Output
6	Tx4p	Transmitter Non-Inverted Data Input	25	Rx4p	Receiver Non-Inverted Data Output
7	GND	Ground	26	GND	Ground
8	ModSelL	Module Select	27	ModPrsL	Module Present
9	ResetL	Module Reset	28	IntL	Interrupt
10	Vcc Rx	+3.3V Power Supply Receiver	29	Vcc Tx	+3.3V Power Supply Transmitter
11	SCL	2-wire Serial Interface Clock	30	Vcc1	+3.3V Power Supply
12	SDA	2-wire Serial Interface Data	31	LPMode	Low Power Mode
13	GND	GND	32	GND	Ground
14	Rx3p	Receiver Non-Inverted Data Output	33	Tx3p	Transmitter Non-Inverted Data Input
15	Rx3n	Receiver Inverted Data Output	34	Tx3n	Transmitter Inverted Data Input
16	GND	Ground	35	GND	Ground
17	Rx1p	Receiver Non-Inverted Data Output	36	Tx1p	Transmitter Non-Inverted Data Input
18	Rx1n	Receiver Inverted Data Output	37	Tx1n	Transmitter Inverted Data Input
19	GND	Ground	38	GND	Ground

Notes:

- GND is the symbol for signal and supply (power) common for the QSFP28 module. All are common within the module and all module voltages are referenced to this potential unless otherwise noted. Connect these directly to the host board signal common ground plane.
- VccRx, Vcc1 and VccTx are the receiving and transmission power suppliers and shall be applied concurrently.
- Vcc Rx, Vcc1 and Vcc Tx may be internally connected within the module in any combination. The connector pins are each rated for a maximum current of 1000 mA.

QSFP28 Module Pad Layout

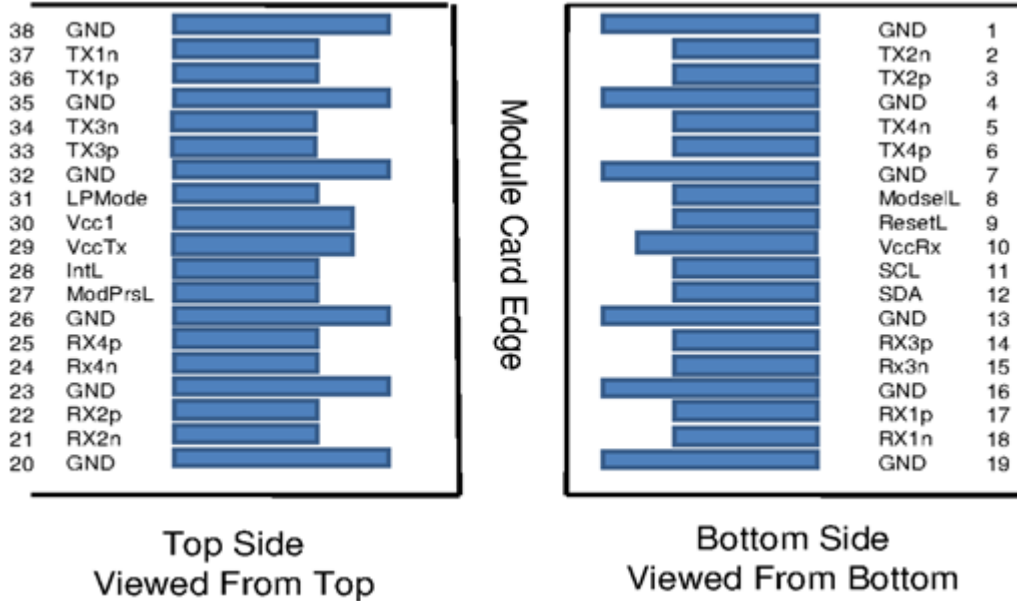

Control Signals

This transceiver is SFF-8636 compliant. This means that the control signals shown in the pad layout support the following functions:

Name	Function	Description
ModPrsL	Output, asserted low	Module Present pin, grounded inside the module. Terminated with pull-up in the host system. Asserted low when the transceiver is inserted, whereby the host detects the presence of the transceiver.
ModSelL	Input, asserted Low	Module Select input pin, terminated high in the module. Only when held low by the host, the module responds to 2-wire serial communication commands. The ModSelL enables multiple modules to share a single 2-wire interface bus.
ResetL	Input, asserted Low	Reset input pin, pulled high in the module. A low level on the ResetL pin for longer than the minimum pulse length (t_Reset_init) initiates a complete module reset, returning all user module settings to their default state. During reset the host shall disregard all status bits until the module indicates completion of the reset interrupt by asserting IntL signal low with the Data_Not_Ready bit negated. Note that on power up (including hot insertion) the module completes the reset interrupt without requiring a reset.

Name	Function	Description
LPMODE	Input, asserted high	Low Power Mode input, pulled up inside the module. The transceiver starts up in low-power mode, i.e. <1.5 W with the two-wire interface active. The host system can read the power class declaration from the transceiver and determine if it has enough power to enable the high-speed operation/ high power mode of the transceiver. This can be done by asserting LPMODE low or by use of the Power_over-ride and Power_set control bits (Address A0h, byte 93 bits 0,1).
INTL	Output, asserted low	Interrupt Low is an open-collector output, terminated high in the host system. A “Low” indicates a possible module operational fault or a status critical to the host system, e.g. temperature alarm. The host identifies the source of the interrupt using the 2-wire serial interface. The INTL pin is de-asserted “High” after completion of reset, when byte 2 bit 0 (Data Not Ready) is read with a value of ‘0’.

The low-speed signals are Low Voltage TTL (LVTTTL) compliant (except for SCL and SDA signals).

Diagnostics and Other Features

The transceiver complies with the SFF-8665 specification and has the following key features:

Physical layer link optimization:

- Programmable Tx input equalization
- Programmable Rx output amplitude
- Programmable Rx output pre-emphasis
- Tx/Rx CDR control
by default enabled for 100 GbE operation, disable it for 40G operation

Digital Diagnostic Monitoring (DDM):

- Rx receive optical power monitor for each lane
- Tx transmit optical power monitor for each lane
- Tx bias current monitor for each lane
- Supply voltage monitor
- Transceiver case temperature monitor
- Warning and Alarm thresholds for each DDM function (not user changeable)

Other SFF-8636 functions and interrupt indications:

- Tx & Rx LOS indication
- Tx & Rx LOL indication
- Tx fault indication

LOS, LOL, and Tx Fault status flags can be read via the two-wire management interface and are jointly transmitted via the INTL output pin. Relevant advertisement, threshold, and readout registers are found in the SFF-8636 MSA.

Specifications

Absolute Maximum Specifications

Absolute maximum ratings are those beyond which permanent damage to the device may occur.

Parameter	Min	Max	Units
Supply voltage	-0.3	3.6	V
Data input voltage	-0.3	3.465	V
Control input voltage	-0.3	4	V
Damage Threshold, per optical lane	3.4	---	dBm
Storage temperature	-40	85	°C

Recommended Operating Conditions and Power Supply Requirements

Parameter	Min	Typ	Max	Units
Supply voltage	3.135	3.3	3.465	V
Power consumption (no retiming)	---	1.5	1.8	W
Power consumption (retiming on all lanes)	---	2.2	2.5	W
Supply noise tolerance (10 Hz - 10 MHz)	66	---	---	mVpp
Operating case temperature	0	---	70	°C
Operating relative humidity	5	---	85	%

Electrical Specifications

Parameter (per lane)	Min	Typ	Max	Units	Notes
Signaling rate (with retiming)	-100ppm	25.78125	+100ppm	Gb/s	---
Signaling rate (without retiming)	0.3		25.784	Gb/s	---
Transmitter					
Differential data input swing at TP1a	IEEE 802.3bm 83E.3.4.1	---	900	mVpp	1
Differential input return loss	Meets equation (83E-5) in IEEE 802.3bm			dB	---
Receiver					
Differential output return loss	Meets equation (83E-5) in IEEE 802.3bm			dB	---
Differential data output swing at TP4	300	---	480	mVpp	---

Parameter (per lane)	Min	Typ	Max	Units	Notes
Common mode output return loss	---	---	-6	dB	---
Output eye width (EW15)	0.57	---	---	UI	---
Output eye height (EH15)	228	---	---	mV	---
Output transition time, 20 to 80%	17	---	---	ps	---
Output eye crossing	45	---	---	%	---

Note 1: Min requires optimization of the input equalizer.

Optical Specifications

Parameter	Min	Typ	Max	Units	Notes
Transmitter (per lane)					
Signaling speed (with retiming)	-100ppm	25.78125	+100ppm	Gb/s	---
Signaling speed (without retiming)	0.3	---	25.7840	Gb/s	---
Center wavelength	840	---	860	nm	---
Average launch power	-8.4	---	2.4	dBm	---
Transmit OMA	-6.4	---	3	dBm	---
Extinction Ratio	2	---	---	dB	---
Transmitter and dispersion eye closure	---	---	4.3	dB	---
Average launch power at Tx squelched	---	---	-30	dBm	---
Eye crossing	45	---	55	%	---
Optical return loss tolerance	---	---	12	dB	---
Transmitter eye mask definition {X1, X2, X3, Y1, Y2, Y3} Hit ratio $1.5 \cdot 10^{-3}$ hits per sample	{0.3, 0.38, 0.45, 0.35, 0.41, 0.5}			---	
Reach on OM3 multi-mode fiber	70	---	---	m	---
Reach on OM4 multi-mode fiber	100	---	---	m	---
Receiver (per lane)					
Signaling speed (with retiming)	-100ppm	25.78125	+100ppm	Gb/s	---
Signaling speed (without retiming)	0.3	---	25.784	Gb/s	---
Center wavelength	840	---	860	nm	---
Receiver reflectance	---	---	-12	dB	---
LOS de-Assert	---	---	-12	dBm	---
LOS assert	-30	---	---	dBm	---
LOS hysteresis	0.5	---	---	dB	---
Unstressed receiver sensitivity (OMA) at BER 10^{-12}	---	---	-7	dBm	1, 4

Parameter	Min	Typ	Max	Units	Notes
Stressed receiver sensitivity (OMA), each lane	---	---	-5.2	dBm	2
Conditions for stressed receiver sensitivity	See below				3
Test Conditions					
Stressed eye closure (SEC), lane under test	4.3			dB	---
Stressed eye J2 Jitter, lane under test	0.39			UI	---
Stressed eye J4 Jitter, lane under test (max)	0.53			UI	---
OMA of each aggressor lane	3			dBm	---
Stressed receiver eye mask definition {X1, X2, X3, Y1, Y2, Y3} Hit ratio 5×10^{-5} hits per sample	{0.28, 0.5, 0.5, 0.33, 0.33, 0.4}			---	---

Notes:

1. All Tx channels on and all Rx channels on with AOP 3dB greater than the tested channel. Injected optical eye must comply with the transmitter eye mask definition from the table.
2. Measured with conformance test signal at TP3 (ref. IEEE 802.3 100GBASE-SR4) for BER < $5 \cdot 10^{-5}$
3. The test conditions are for measuring stressed receiver sensitivity only - not characteristics of the receiver.
4. For revision A4 or lower, Max is -6dBm.

Electrostatic Discharge (ESD)

This product is compatible with ESD levels in typical data center operating environments and certified in accordance with the standards listed in the Regulatory Compliance Section. The product is shipped with protective caps on all connectors to protect it during shipping. In normal handling and operation of high-speed cables and optical transceivers, ESD is of concern during insertion into the OSFP cage of the server/switch. Hence, standard ESD handling precautions must be observed. These include use of grounded wrist/shoe straps and ESD floor wherever a cable/transceiver is extracted/inserted. Electrostatic discharges to the exterior of the host equipment chassis after installation are subject to system level ESD requirements.

Handling and Cleaning

The transceiver can be damaged by exposure to current surges and over voltage events. Take care to restrict exposure to the conditions defined in Absolute Maximum Ratings. Observe normal handling precautions for electrostatic discharge-sensitive devices. The transceiver is shipped with dust caps on both the electrical and the optical port. The cap on the optical port should always be in place when there is no fiber cable connected. The optical connector has a recessed connector surface which is exposed whenever it has no cable nor cap.

Prior to insertion of the fiber cable, clean the cable connector to prevent contamination from it. The dust cap ensures that the optics remain clean and no additional cleaning should be needed. In the event of contamination, standard cleaning tools and methods should be used. Liquids must not be applied.

Mechanical Specifications

Mechanical Dimensions Rev. B1 and Higher

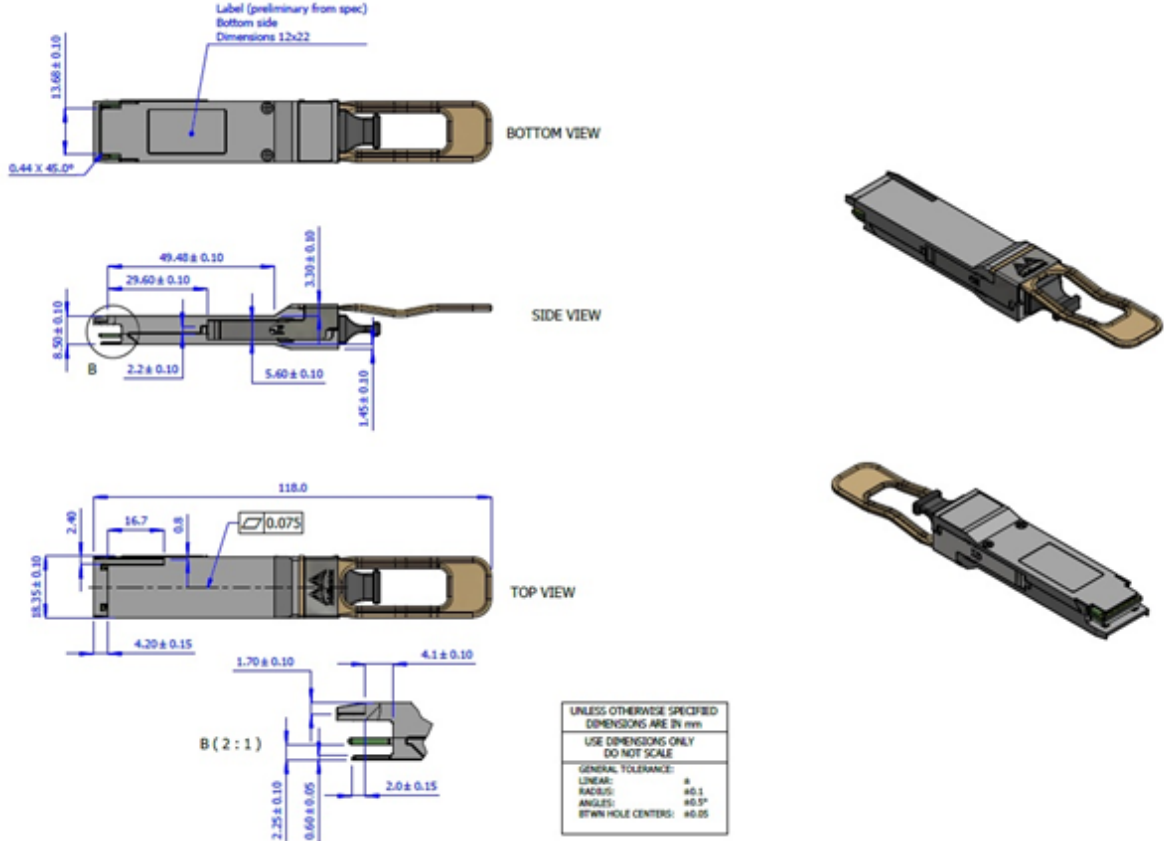

Mechanical Dimensions Rev A4 and Lower

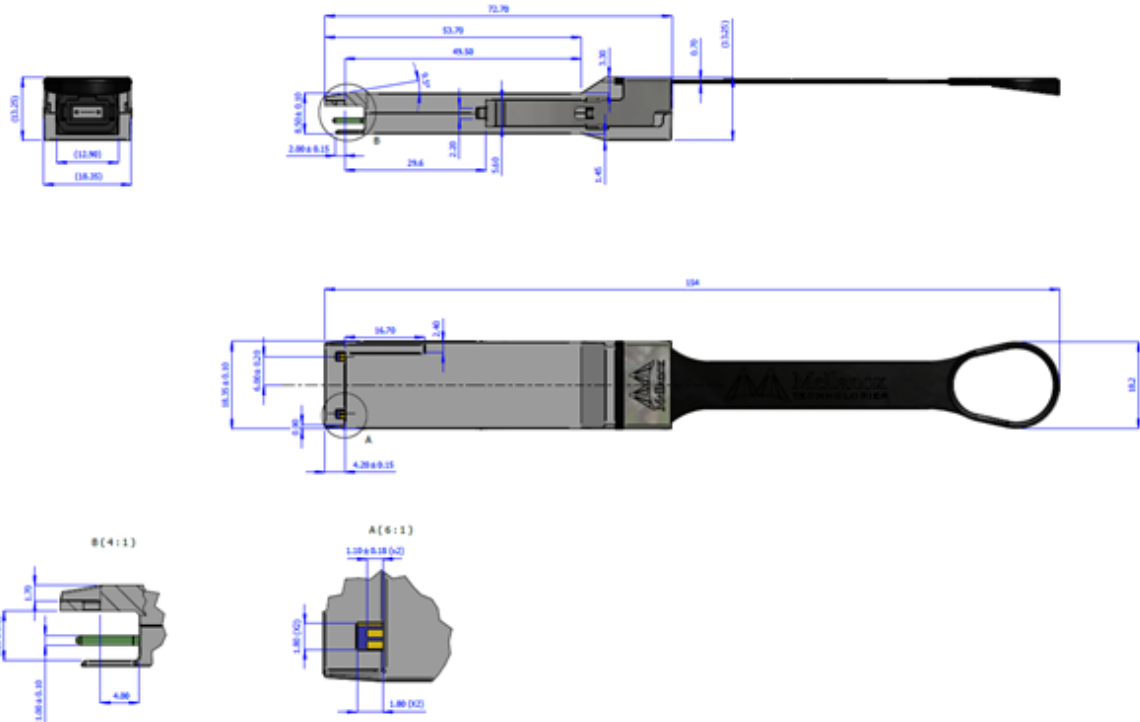

Memory Map

The transceiver's memory map is compliant with the QSFP Management interface specification SFF-8636. See also NVIDIA LinkX[®] Memory Map Application Note (MLNX-15-5926).

Label

The following label is applied on the transceiver's backshell:

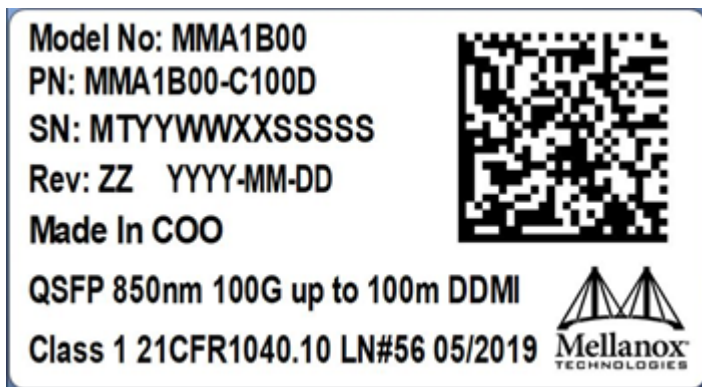

(sample illustration)

Backshell Label Legend

Symbol	Meaning	Notes
SN	Serial Number	

Symbol	Meaning	Notes
MT	Manufacturer name	2 characters (MT)
YY	Year of manufacturing	2 digits
WW	Week of manufacturing	2 digits
DM	Manufacturer site	2 characters
ZZZZZ	Serial number	5 digits for serial number, starting from 00001. Reset at start of week to 00001.
Miscellaneous		
ZZ	HW and SW revision	2 alpha-numeric characters
YYYY	Year of manufacturing	4 digits
MM	Month of manufacturing	2 digits
DD	Day of manufacturing	2 digits
COO	Country of origin	E.g. China or Malaysia
	Quick response code	Serial number (MTYYWWXXSSSSS)

Regulatory Compliance and Classification

The laser module is classified as class I according to IEC 60825-1, IEC 60825-2 and 21 CFR 1040 (CDRH).

- Safety: FDA/CDRH, TUV, UL/CSA, ACMA
- EMC: ITL

Ask your NVIDIA FAE for a zip file of all the certifications for this product.

FCC Class A Notice

Each of the devices complies with CFR47 FCC Class A Part 15 of the FCC Rules. Operation is subject to the following two conditions:

1. This device may not cause harmful interference.
2. This device must accept any interference received, including interference that may cause undesired operation.

Note: This equipment has been tested and found to comply with the limits for a Class A digital device, pursuant to Part 15 of the FCC Rules. These limits are designed to provide reasonable protection against harmful interference in a residential installation. This equipment generates, uses and can radiate radio frequency energy and, if not installed and used in accordance with the instructions, may cause harmful interference to radio communications. However, there is no guarantee that interference will not occur during installation. If this equipment does cause harmful interference to radio or television reception, which can be determined by turning the equipment off and on, the user is encouraged to try to correct the interference by one or more of the following measures:

- Reorient or relocate the receiving antenna.
- Increase the separation between the equipment and receiver.

- Connect the equipment into an outlet on a circuit different from that to which the receiver is connected.
- Consult the dealer or an experienced radio/television technician for help.

Modifications: Any modifications made to this device that are not approved by NVIDIA may void the authority granted to the user by the FCC to operate this equipment.



Ordering Information

Ordering Part Number	Description
MMA1B00-C100D	Transceiver, 100GbE, QSFP28, MPO, 850nm, SR4, up to 100m, DDMI

References

1. SFF-8665: “QSFP+ 28Gb/s 4X Pluggable Transceiver Solution (QSFP28)”, and associated SFF documents) available at <http://www.snia.org/sff/specifications>.
 - a. SFF-8661
 - b. SFF-8679
 - c. SFF-8636
 - d. SFF-8662
 - e. SFF-8663
 - f. SFF-8672
 - g. SFF-8683
2. IEEE 802.3ba, PMD Type 100GBASE-SR4.
3. IEEE 802.3bm, Annex 83E, CAUI-4 Interface.
4. Cable and Transceiver Handling and FAQ - Mellanox/Nvidia Application Note (MLNX-15-3603)
5. Measuring eye Parameters - NVIDIA Application Note (MLNX-15-5400)
6. LinkX[®] Memory Map - NVIDIA Application Note (MLNX-15-5926)

For further information, please contact your sales representative or the NVIDIA support team.

Appendix: Optical Connector and Patch Cable

Optical Connector

The optical port in the parallel 2x 4-lane optical transceiver is a male MPO connector with alignment pins, mating with fiber-optic cables with female MPO connector. The connector contains a 12-channel MT ferrule.

QSFP28 Optical Male MPO Connector of the Transceiver (front view)

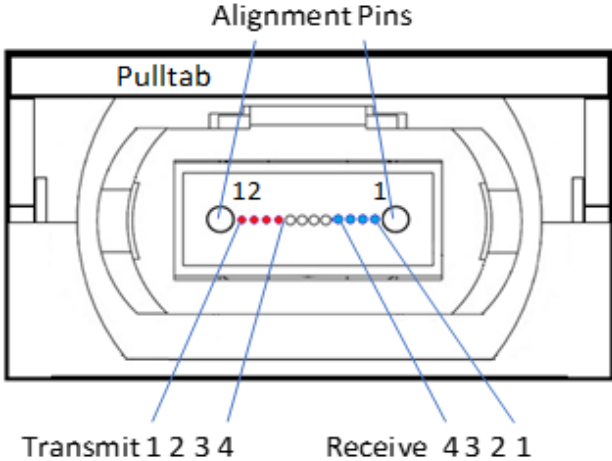

Female MPO Cable Connector

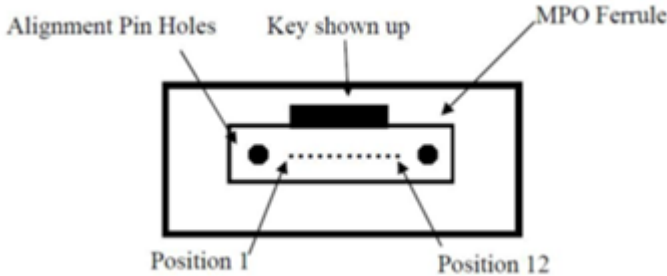

Reference: IEC specification IEC 61754-7.

Patch Cable

The fiber which connects with Transceiver A's lane 1 must end at Transceiver B's lane 12 at the far end of the cable. For example, position 1 of MPO connector A at the near end of the cable connects to position 12 of the far end MPO connector B. This calls for a 'crossed' MPO cable, which is often referred to as patch cable type B. See interconnect scheme below.

MPO to MPO Patch Cable Fiber Connections

Connector A	Connection	Connector B
1	<--	12

Connector A	Connection	Connector B
2	<--	11
3	<--	10
4	<--	9
5	Not Connected	8
6	Not Connected	7
7	Not Connected	6
8	Not Connected	5
9	-->	4
10	-->	3
11	-->	2
12	-->	1

As shown in the above table, the 4 middle positions are not in use, indicating that the cable may have 8 or 12 fibers. Only 8 fibers are used.

The fiber is a standard OM3 or OM4 multi-mode fiber. The maximum length is detailed in the [Optical Specifications](#) section.

MPO Fiber Patch Cables OM3 (left) and OM4 (right)



OM4 cables may have aqua or pink colored connectors, depending on the make and model.

NVIDIA does not provide MPO patch cables. Multiple cable vendors provide these patch cables.

Multiple MPO patch cables can be connected in a series, e.g. via Optical Distribution Frames (ODFs). Each added connector pair increases modal dispersion and reflections in the link which impairs performance. An odd number of ‘crosses’ must be used between transceivers at the two ends.

Document Revision History

Version	Date	Description of Change
1.7	Nov. 2021	Reformatted and rebranded; migrated to HTML.
1.6	Apr. 2021	Removed “BER better than 10^{-15} ” from Key Features. Added Electrostatic Discharge (ESD) and Handling and Cleaning sections. Updated Transmit OMA, Extinction Ratio, and Transmitter and dispersion eye closure values in the Optical Specifications table. Updated document template, legal notice, and introduction.
1.5	Nov. 2020	Added: Control Signals description, optical connector interface information in Appendix A and added References section. Updated DDM info under Diagnostics and Other Features and the Regulatory Compliance and Classification list. Minor text edits. Updated Label.
1.4	Sep. 25, 2017	Updated the Absolute Maximum Ratings table - Supply voltage Max changed from 3.465 to 3.6V.
1.1 - 1.3	Aug. 2016-2017	Refer to rev. 1.5 of this datasheet for the changes.
1.0	March 2016	Initial release

Notice

This document is provided for information purposes only and shall not be regarded as a warranty of a certain functionality, condition, or quality of a product. Neither NVIDIA Corporation nor any of its direct or indirect subsidiaries and affiliates (collectively: "NVIDIA") make any representations or warranties, expressed or implied, as to the accuracy or completeness of the information contained in this document and assumes no responsibility for any errors contained herein. NVIDIA shall have no liability for the consequences or use of such information or for any infringement of patents or other rights of third parties that may result from its use. This document is not a commitment to develop, release, or deliver any Material (defined below), code, or functionality.

NVIDIA reserves the right to make corrections, modifications, enhancements, improvements, and any other changes to this document, at any time without notice. Customer should obtain the latest relevant information before placing orders and should verify that such information is current and complete.

NVIDIA products are sold subject to the NVIDIA standard terms and conditions of sale supplied at the time of order acknowledgement, unless otherwise agreed in an individual sales agreement signed by authorized representatives of NVIDIA and customer ("Terms of Sale"). NVIDIA hereby expressly objects to applying any customer general terms and conditions with regards to the purchase of the NVIDIA product referenced in this document. No contractual obligations are formed either directly or indirectly by this document.

NVIDIA products are not designed, authorized, or warranted to be suitable for use in medical, military, aircraft, space, or life support equipment, nor in applications where failure or malfunction of the NVIDIA product can reasonably be expected to result in personal injury, death, or property or environmental damage. NVIDIA accepts no liability for inclusion and/or use of NVIDIA products in such equipment or applications and therefore such inclusion and/or use is at customer's own risk.

NVIDIA makes no representation or warranty that products based on this document will be suitable for any specified use. Testing of all parameters of each product is not necessarily performed by NVIDIA. It is customer's sole responsibility to evaluate and determine the applicability of any information contained in this document, ensure the product is suitable and fit for the application planned by customer, and perform the necessary testing for the application in order to avoid a default of the application or the product. Weaknesses in customer's product designs may affect the quality and reliability of the NVIDIA product and may result in additional or different conditions and/or requirements beyond those contained in this document. NVIDIA accepts no liability related to any default, damage, costs, or problem which may be based on or attributable to: (i) the use of the NVIDIA product in any manner that is contrary to this document or (ii) customer product designs.

No license, either expressed or implied, is granted under any NVIDIA patent right, copyright, or other NVIDIA intellectual property right under this document. Information published by NVIDIA regarding third-party products or services does not constitute a license from NVIDIA to use such products or services or a warranty or endorsement thereof. Use of such information may require a license from a third party under the patents or other intellectual property rights of the third party, or a license from NVIDIA under the patents or other intellectual property rights of NVIDIA.

Reproduction of information in this document is permissible only if approved in advance by NVIDIA in writing, reproduced without alteration and in full compliance with all applicable export laws and regulations, and accompanied by all associated conditions, limitations, and notices.

THIS DOCUMENT AND ALL NVIDIA DESIGN SPECIFICATIONS, REFERENCE BOARDS, FILES, DRAWINGS, DIAGNOSTICS, LISTS, AND OTHER DOCUMENTS (TOGETHER AND SEPARATELY, "MATERIALS") ARE BEING PROVIDED "AS IS." NVIDIA MAKES NO WARRANTIES, EXPRESSED, IMPLIED, STATUTORY, OR OTHERWISE WITH RESPECT TO THE MATERIALS, AND EXPRESSLY DISCLAIMS ALL IMPLIED WARRANTIES OF NONINFRINGEMENT, MERCHANTABILITY, AND FITNESS FOR A PARTICULAR PURPOSE. TO THE EXTENT NOT PROHIBITED BY LAW, IN NO EVENT WILL NVIDIA BE LIABLE FOR ANY DAMAGES, INCLUDING WITHOUT LIMITATION ANY DIRECT, INDIRECT, SPECIAL, INCIDENTAL, PUNITIVE, OR CONSEQUENTIAL DAMAGES, HOWEVER CAUSED AND REGARDLESS OF THE THEORY OF LIABILITY, ARISING OUT OF ANY USE OF THIS DOCUMENT, EVEN IF NVIDIA HAS BEEN ADVISED OF THE POSSIBILITY OF SUCH DAMAGES. Notwithstanding any damages that customer might incur for any reason whatsoever, NVIDIA's aggregate and cumulative liability towards customer for the products described herein shall be limited in accordance with the Terms of Sale for the product.

Trademarks

NVIDIA, the NVIDIA logo, and Mellanox are trademarks and/or registered trademarks of NVIDIA Corporation and/or Mellanox Technologies Ltd. in the U.S. and in other countries. Other company and product names may be trademarks of the respective companies with which they are associated.



Copyright

© 2023 NVIDIA Corporation & affiliates. All Rights Reserved.

