



NVIDIA MetroX-3 XC TQ8400 Long-haul 1U Appliance User Manual

Table of Contents

1	Introduction.....	6
1.1	Product Overview.....	6
1.1.1	NVIDIA MetroX-3 XC Highlights.....	7
1.2	Main System Components.....	7
1.3	System Features	8
1.4	Operating Systems.....	8
1.5	Certifications	8
2	System Layout and Interfaces	9
2.1	NVIDIA MetroX-3 XC Front Panel	9
2.2	NVIDIA MetroX-3 XC Rear Panel.....	10
2.3	Interfaces Detailed Description.....	11
2.3.1	Power-On LED.....	11
2.3.2	USB 2.0 and 3.0 Interfaces.....	11
2.3.3	PCIe Gen 4.0 Slots.....	11
2.3.4	LAN Interfaces.....	11
2.3.5	Redundant Power Module.....	12
2.3.6	Fans.....	12
2.3.6.1	Power Supply Fans	12
2.3.6.2	Internal Fans	12
3	Hardware Installation.....	13
3.1	MetroX-3 XC Installation	13
3.1.1	Safety Warnings	14
3.1.2	Taiwan RoHS Declaration - Switch Systems	16
3.1.2.1	Restricted Substances Presence Condition (Declaration Table)	16
3.1.3	Taiwan RoHS Declaration - Gateway Systems.....	17
3.1.3.1	設備名稱 (Equipment Name)： 閘道器 (Gateway).....	17
3.1.4	Taiwan BSMI Class A Statement - Warning to the User!	17
3.1.5	System Requirements	17
3.1.5.1	Hardware Requirements	17
3.1.5.2	Airflow Requirements	18
3.1.5.3	Software Requirements.....	18
3.1.6	Unpacking the Package.....	18
3.1.6.1	Safety Precautions.....	18
3.1.6.2	Package Contents	18
3.1.6.3	Installing the Appliance in Rack.....	19
3.2	Connecting the Appliance to the Network/Fabric	21

3.3	Grounding the Appliance	21
3.4	Power Connections and Initial Power On	22
3.5	Replacing the SSD	24
3.6	Disassembly of the System from the Rack	25
3.7	Removing the Battery	25
3.8	Disposal.....	26
3.9	Cable Installation	26
3.9.1	Power Cable	26
3.9.2	ConnectX-7 Networking Cards Cables.....	26
3.10	Initial Power-On.....	28
3.11	System Maintenance.....	28
3.11.1	Power Supply Units.....	28
3.11.1.1	Extracting and Inserting the Power Supply Unit.....	29
4	Configuring the Gateway for the First Time	30
4.1	MetroX Initialization.....	30
4.1.1	Rerunning the Wizard.....	34
4.1.2	Starting the Command Line Interface (CLI).....	35
5	System Monitoring	37
5.1	Right Control Panel	37
5.2	Left Control Panel View	37
5.2.1	System Status LEDs.....	37
5.2.2	System Health and System ID Indicator Codes	38
5.3	SSD LED Indicators	39
5.4	Rear Panel Monitoring Interfaces	40
5.4.1	RJ-45 Remote Management Port.....	40
5.4.2	RJ-45 Management Ports eth0-eth1	40
5.4.3	ConnectX-7 OSFP Ports	40
5.4.4	RJ-45 Ethernet Connector for Remote Management.....	41
5.4.5	USB Interface.....	41
5.4.6	PSU Status Indicators	42
5.4.7	NIC Activity LED Indicators.....	43
5.5	Air Flow	44
6	Troubleshooting.....	45
6.1	General Troubleshooting.....	45
7	Technical Specifications.....	46
7.1	MTQ8400 Specifications	46

7.2	Thermal Threshold Definitions.....	47
8	Inventory Information.....	48
9	Field Replaceable Units.....	49
10	Revision History.....	50

About this Manual

This manual describes the installation and basic use of NVIDIA® MetroX®-3 XC long-haul 1U appliance.

Ordering Part Numbers

The table below provides the ordering part number (OPN) for the available NVIDIA MetroX-3 XC systems.

NVIDIA SKU	Legacy OPN	Marketing Description	Lifecycle Phase
920-9B020-00 FA-0DZ	MTQ8400- HS2R	NVIDIA MetroX-3 XC long-haul 100Gb/s bandwidth, 1U system, ready for DWDM systems, 2x long-haul QSFP12 ports, secured boot, 2x power supplies (AC), standard depth, rail kit.	EoL (End of Life)
920-9B020-00 FA-6DZ	MTQ8400- HS2RC	NVIDIA MetroX-3 XC long-haul 100Gb/s bandwidth, 1U system ready for DWDM systems, 2x long-haul QSFP12 ports, secured boot, crypto-enabled, 2x power supplies (AC), standard depth, rail kit.	EoL (End of Life)

Intended Audience

This manual is intended for IT managers and system administrators.

Related Documentation

Document	Description
NVIDIA NVDA-OS-XC User Manual for NVIDIA MetroX-3 XC Appliance	This document contains information regarding the configuration and management of the MetroX-3 XC appliance software.

Revision History

A list of the changes made to this document are provided in [Document Revision History](#).

1 Introduction

This is the user guide for NVIDIA® MetroX®-3 XC product family. This document contains the complete product overview, installation and initialization instructions, and product specifications.

 This document is preliminary and subject to change.

1.1 Product Overview

The NVIDIA® MetroX®-3 XC (Xternal Connect) long-haul system seamlessly and securely extends the reach of the NVIDIA Quantum InfiniBand networking platform, providing high data throughput, In-Network Computing, and native remote direct-memory access (RDMA) communications. Enhancing data security, MetroX-3 XC provides encrypted connectivity over long distances and dense wavelength-division multiplexing (DWDM) infrastructures. MetroX-3 XC can extend the reach of InfiniBand up to 40 kilometers, enabling connectivity between remote data centers, from edge infrastructures to data centers, or between data centers and remote storage infrastructures for high availability and disaster recovery.

MetroX-3 XC guarantees high-performance, high-volume data sharing. Users can easily migrate application jobs from one InfiniBand-based data center to another or combine the compute power of multiple remote data centers together for higher overall performance and scalability. MetroX-3 XC is designed for today's business continuity and simplified disaster recovery. It comes as an appliance with four ports: Two provide connectivity to the local InfiniBand network; the other two provide long-haul connectivity into a DWDM infrastructure. In addition to enabling data center expansion, disaster recovery, data mirroring, and campus connectivity, select models of MetroX-3 XC systems support long-haul security by encrypting the transmitted data.

The MetroX-3 XC system comes with built-in chassis management (MLNX-XC) software, including administrative tools to manage firmware, power supplies, fans, ports, and other system interfaces. The MetroX-3 XC software's GUI-based web management provides full alarm, event history, activities log, and performance monitoring for all optical modules.



1.1.1 NVIDIA MetroX-3 XC Highlights

For a list of NVIDIA MetroX-3 XC highlights, refer to [the system's datasheet](#).

1.2 Main System Components

The NVIDIA MetroX-3 XC system populate the following components:

- Three ConnectX-7 network interface cards (NICs) which enable the hardware-based forwarding of IP packets from the InfiniBand to Ethernet, and vice versa.
- Two redundant, load-sharing power supply units at the rear side of the system. The PSUs are housed in a 2U canister. Each PSU has an extraction handle, PSU status LED and a power socket.
 - One fan per power supply unit on the rear panel of the appliance.
- Six internal fans for cooling the CPU and expansion cards. Under normal operation, the cooling fans operate at a constant speed. If the system module fails or one of the temperature thresholds is exceeded, the cooling fans automatically raise their rotation speeds to draw more airflow.

Management Interfaces, PSUs, and Fans

Processor System	CPU Type	Intel Xeon Gold 6240R /2.4GHz /36MB /24 Cores 185W TDP
	Memory Type	DIMMs DDR4 3200MHz ECC
	Memory Size	12 x 8GB
	Error Detection	<ul style="list-style-type: none">• Corrects single-bit errors• Detects double-bit errors (using ECC memory)
Rear I/O Panel	USB	1x USB 3.0 and 1x USB 2.0
	RJ-45/LAN	4 x RJ-45 LAN ports: <ul style="list-style-type: none">• 2x 10GbE• 2x 1GbE/IPMI-LAN
On-board Devices	Remote Management Port	Sharing with the LAN 1/4.
Expansion slots	PCI-Express	3x Network Interface cards
Cooling	Chassis Fan	4 dual set hot swappable internal fans for CPU and expansion cards cooling.
	PSU Fans	One fan per power supply unit
PC Health Monitoring	Voltage	Monitors for CPU Cores, +3.3V PG, +5V PG, 1.05 PG, VBAT PG

	Temperature	Monitoring for CPU0 & CPU1 (PECI) Monitoring for System (HWM)
	Other Features (Case Open)	Chassis intrusion detection

1.3 System Features

For a full list of features, please refer to [the system's datasheet](#).

1.4 Operating Systems

NVIDIA MetroX-3 XC includes the NVIDIA Gateway Operating System, MLNX-GW, which manages the appliance and handles the high availability and load balancing between the ConnectX cards and between gateway appliances. For a detailed description of MLNX-GW, please contact your NVIDIA representative.

1.5 Certifications

The list of certifications per system for different regions of the world (such as EMC, safety, and others) is located on the NVIDIA Networking website at <https://www.nvidia.com/en-us/networking/environmental-and-regulatory-compliance/>.

2 System Layout and Interfaces

Unknown macro: 'easy-heading-free'

The figures below show the front and rear sides of NVIDIA Metro3-2 XC. Each numbered interface that is referenced in the figures is described in the following table.

⚠ For additional information on the monitoring interfaces in the front and rear panel, see [System Monitoring](#).

2.1 NVIDIA MetroX-3 XC Front Panel

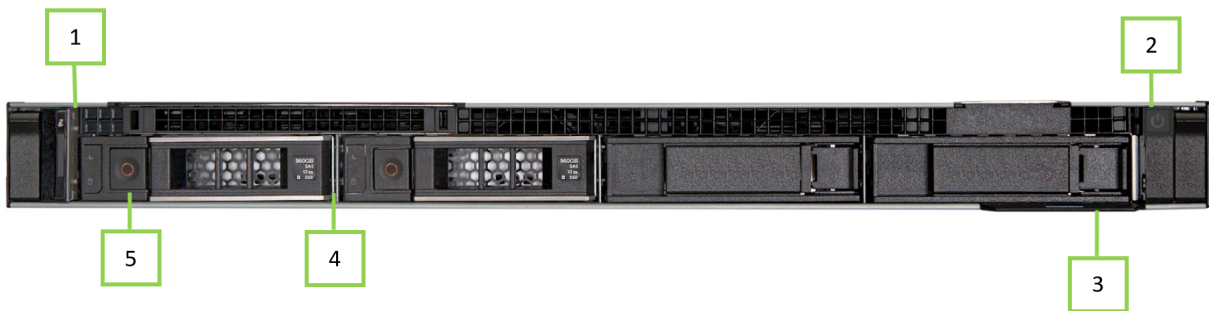

Item	Interface	Description
1	Left control panel	Contains the system health, system ID, and status LED
2	Right control panel	Contains the power button
3	Pull-tab	A slide-out label panel containing system information (e.g., MAC address, serial number, etc.)
4	SSD (FRU)	SSD number 1
5	SSD (FRU)	SSD number 0

2.2 NVIDIA MetroX-3 XC Rear Panel

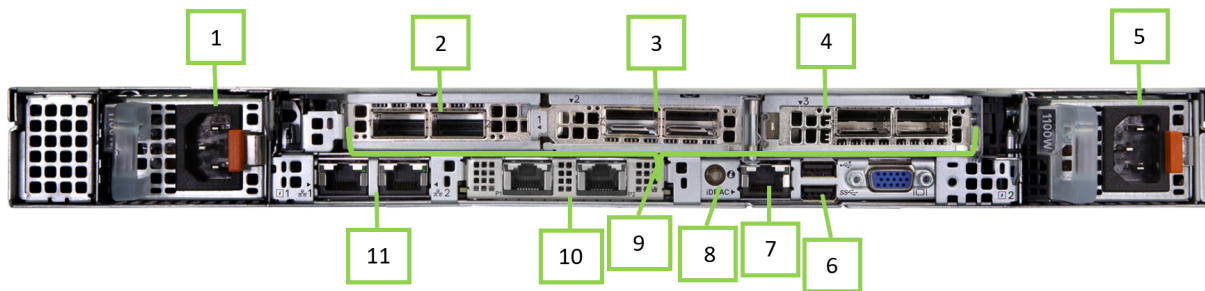

Item	Interface	Description
1	Power supply unit (FRU)	PSU 1
2	PCIe expansion card riser (slot 1)	The expansion card riser enables to connect PCIe expansion cards
3	PCIe expansion card riser (slot 2)	The expansion card riser enables to connect PCIe expansion cards
4	USB 2.0 port	USB 2.0-compliant
5	Power supply unit (FRU)	PSU 2
6	USB 3.0 port	USB 3.0-compliant
7	remote management dedicated port	The remote management is designed for secure local and remote server management, and helps IT administrators deploy, update and monitor the device.
8	System identification button	<p>Press the system ID button:</p> <ul style="list-style-type: none"> To locate a particular system within a rack To turn the system ID on or off To reset remote management (press and hold for more than 16 seconds) <div style="border: 1px solid orange; padding: 5px; margin: 5px 0;"> <p>⚠ To reset remote management using system ID, ensure that the system ID button is enabled in the remote management setup.</p> </div> <div style="border: 1px solid orange; padding: 5px; margin: 5px 0;"> <p>⚠ If the system stops responding during POST, press and hold the system ID button (for more than 5 seconds) to enter the BIOS progress mode.</p> </div>
9	Adapter cards ports	3x ConnectX-7 adapter cards
10	OCP NIC ports	2x 10GbE Base-T ports
11	NIC ports	2x 1GbE Base-T ports

2.3 Interfaces Detailed Description

2.3.1 Power-On LED

There is one I/O LED (green) on the front panel, to indicate whether the system is powered.

- For Power-On LEDs definitions, please refer to [Power-On LEDs Specifications](#).

2.3.2 USB 2.0 and 3.0 Interfaces

MetroX-3 XC offers four USB 3.0 ports on the system's front panel, and two USB 2.0 ports on the system's rear panel.

The USB interfaces can be used to provide bandwidth of up to 500MB/s to shorten the time of data transmission.



Do not use excessive force when inserting or extracting the USB disk to and from the connector.

2.3.3 PCIe Gen 4.0 Slots

MetroX-3 XC is shipped assembled with three ConnectX-7 VPI cards that enable the hardware-based forwarding of IP packets from InfiniBand to Ethernet, and vice versa.

2.3.4 LAN Interfaces

The appliance has two 10G Base-T Ethernet LAN 1/2 connections - Intel X557 PHY (2* 10GbE) and two GbE LAN 3/4 - Intel I210 (2* 10/100/1000 Base-T GbE). They eliminate bottlenecks in network data flow. The ports are accessible from the rear panel.

In addition, the appliance is equipped with ASPEED 2500 BMC chip that supports IPMI 2.0 (Intelligent Platform Management Interface 2.0) via LAN1 and LAN4 ports.

The recommended cabling when connecting LAN4 and LAN1 (for 10G LAN) is Cat. 6 (< 55m) or Cat. 6A (<100m) for which both cross and straight cables are supported.

LAN3 (X557-AT2 controller) has an internal signal connected to BMC LAN2.

- For LAN1 and LAN2 LED definitions, please refer to [LAN1 / LAN 2 Rear I/O LED Specifications](#).
- For LAN3 and LAN4 LEDs definitions, please refer to [LAN3 / LAN4 Rear I/O LED Specifications](#).



If any of the LAN ports does not move to "Link Up" state automatically, it is required to set it manually.

2.3.5 Redundant Power Module

NVIDIA MetroX-3 XC is equipped with two redundant power supply units at the rear of the appliance. The PSUs are housed in a 2U canister containing the power supplies. Each PSU has an extraction handle, PSU status LED, and a power socket.

- 80 PLUS Platinum 1+1 redundant power supply
- 1000 W @ 100 ~ 127 V
- 2000 W @ 200 ~ 240 V

For the redundant power module LEDs definitions, please refer to [Power Module LED Specifications](#).

2.3.6 Fans

2.3.6.1 Power Supply Fans

NVIDIA MetroX-3 XC is equipped with one fan per power supply unit on the rear panel of the appliance.

2.3.6.2 Internal Fans

NVIDIA MetroX-3 XC system has an extensive collection of sensors that automatically track thermal activity, which helps regulate temperature, thereby reducing server noise and power consumption. The thermal management of MetroX-3 XC delivers high performance for the right amount of cooling to components at the lowest fan speeds across a wide range of ambient temperatures from 10°C to 35°C (50°F to 86°F) and to extended ambient temperature ranges (see Environmental Specifications). The benefits are lower fan power consumption (lower server system power and data center power consumption) and greater acoustical versatility.

- 4 dual set hot swappable internal fans for CPU and expansion cards cooling

3 Hardware Installation

 Unknown macro: 'easy-heading-free'

The installation of the MetroX-3 XC systems requires attention to the mechanical and power elements of the appliance and precautions must be taken for the rack-mounted equipment.

The system platform can be rack-mounted and is designed for installation in a standard 19" rack. The power side of the system includes a hot-swap power supply unit (PSU), space for an optional second PSU (purchased separately) for redundancy, and replaceable fan trays. There is one possible airflow direction. It is necessary to validate that the system airflow direction is compatible with the system, rack, and PSUs. The rear panel of the system has the QSFP28 ports, system LEDs, and management connection ports.

Use a rack capable of supporting the mechanical and environmental characteristics of a fully-populated platform.

-  The rack mounting holes conform to the EIA-310 standard for 19-inch racks. Take precautions to guarantee proper ventilation in order to maintain good airflow at ambient temperature.

3.1 MetroX-3 XC Installation

The installation procedure of NVIDIA MetroX-3 XC systems involves the following steps.



Step	Procedure	Direct Link
1	Follow safety warning procedures.	Refer to Safety Warnings .
2	Pay attention to the system considerations within the host chassis.	Refer to System Requirements .
3	Follow the safety precautions	Refer to Safety Precautions .
4	Unpack the package and confirm that you have received all the required components.	Refer to Unpacking the Package .
5	Mount the appliance in a rack enclosure.	Refer to Installing the Appliance in the Rack .
6	Use the supplied cables to connect the system	Refer to Cable Installation .
7	Power on the system.	Refer to Initial Power-On .







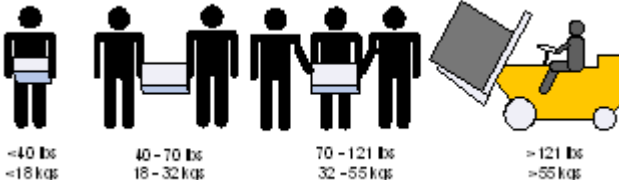





3.1.1 Safety Warnings





Safety warnings are provided here in the English language. For safety warnings in other languages, refer to the Safety Instructions for Gateway document available on mellanox.com.

Please observe all safety warnings to avoid injury and prevent damage to system components. Note that not all warnings are relevant to all models.

	<p>Installation Instructions Read all installation instructions before connecting the equipment to the power source.</p>
	<p>Bodily Injury Due to Weight Use enough people to lift this product safely.</p>  <p style="text-align: center;"> ~40 lbs ~18 kgs 40 - 70 lbs 18 - 32 kgs 70 - 121 lbs 32 - 55 kgs >121 lbs >55 kgs </p>
	<p>Heavy Equipment This heavy equipment should be moved using a mechanical lift to avoid injuries.</p>
	<p>Risk of Electric Shock!</p> <ul style="list-style-type: none"> With the fan module removed power pins are accessible within the module cavity. Do not insert tools or body parts into the fan module cavity. For AC powered switch systems: Disconnecting one power supply only disconnects one module. To isolate the unit completely, all connected power supplies must be disconnected.  <p>In QM97X0/HGX H100 switch systems: for 200-240Vac use only</p>
	<p>Over-temperature This equipment should not be operated in an area with an ambient temperature exceeding the maximum value listed in the product specifications. Moreover, to guarantee proper ventilation, allow at least 8 cm (3 inches) of clearance around the ventilation openings.</p>
	<p>Stacking the Chassis The chassis should not be stacked on any other equipment. If the chassis falls, it can cause bodily injury and equipment damage.</p>
	<p>Redundant Power Supply Connection (OPTIONAL)—Electrical Hazard This product includes a redundant power or a blank in its place. In case of a blank power supply, do not operate the product with the blank cover removed or not securely fastened.</p>
	<p>Double Pole/Neutral Fusing This system has double pole/neutral fusing. Remove all power cords before opening the cover of this product or touching any internal parts.</p>

	<p>Multiple Power Inlets Risk of electric shock and energy hazard. The PSUs are all independent. Disconnect all power supplies to ensure a powered down state inside of the switch platform.</p>
	<p>During Lightning—Electrical Hazard During periods of lightning activity, do not work on the equipment or connect or disconnect cables.</p>
	<p>Copper Cable Connecting/Disconnecting Copper cables are heavy and not flexible, as such they should be carefully attached to or detached from the connectors. Refer to the cable manufacturer for special warnings/instructions.</p>
	<p>Rack Mounting and Servicing When this product is mounted or serviced in a rack, special precautions must be taken to ensure that the system remains stable. In general, the rack should be filled with equipment starting from the bottom to the top.</p>
	<p>Equipment Installation This equipment should be installed, replaced, and/or serviced only by trained and qualified personnel.</p>
	<p>Equipment Disposal Disposal of this equipment should be in accordance to all national laws and regulations.</p>
	<p>Local and National Electrical Codes This equipment should be installed in compliance with local and national electrical codes.</p>
	<p>Installation Codes This device must be installed according to the latest version of the country national electrical codes. For North America, equipment must be installed in accordance to the applicable requirements in the US National Electrical Code and the Canadian Electrical Code.</p>
	<p>Battery Replacement Warning: Replace only with UL Recognized battery, certified for maximum abnormal charging current not less than 4mA. There is a risk of explosion should the battery be replaced with a battery of an incorrect type. Dispose of used batteries according to the instructions.</p>
	<p>UL Listed and CSA Certified Power Supply Cord For North American power connection, select a power supply cord that is UL Listed and CSA Certified, 3 - conductor, [16 AWG], terminated with a molded plug rated at 125 V, [13 A], with a minimum length of 1.5m [six feet] but no longer than 4.5m. For European connection, select a power supply cord that is internationally harmonized and marked “<HAR>”, 3 - conductor, minimum 1.0 mm² wire, rated at 300 V, with a PVC insulated jacket. The cord must have a molded plug rated at 250 V, 10 A.</p>
	<p>Installation Codes This device must be installed according to the latest version of the country's national electrical codes. For North America, equipment must be installed in accordance to the applicable requirements in the US National Electrical Code and the Canadian Electrical Code.</p>
	<p>Interconnection of Units Cables for connecting to the unit RS232 and Ethernet Interfaces must be UL certified type DP-1 or DP-2. (Note: when residing in non LPS circuit.)</p>
	<p>Overcurrent Protection A readily accessible Listed branch circuit overcurrent protective device rated 20 A must be incorporated in the building wiring.</p> <p>Acoustic Level Warning The acoustic level listed in Specifications section represents product noise measured in accordance with ISO 7779 under nominal conditions. The actual noise level can vary depending on the installation conditions, including but not limited to the number of racks in the installation, the overall installation size, rack and other equipment material and noise levels, fan faults, room temperature, room configuration, and employee location in relation to the equipment. The data-center owner should manage effective hearing conservation as per the OSHA standard to protect employees against over and extended exposure to noise.</p>

	<p>Do Not Use the Switch as a Shelf or Work Space</p> <p>Caution: Slide/rail mounted equipment is not to be used as a shelf or a work space. The rails are not intended for sliding the unit away from the rack. It is for permanent installation at final resting place only, not used for service and maintenance.</p>
	<p>WEEE Directive</p> <p>According to the WEEE Directive 2002/96/EC, all waste electrical and electronic equipment (EEE) should be collected separately and not disposed of with regular household waste. Dispose of this product and all of its parts in a responsible and environmentally-friendly way.</p>
	<p>Country of Norway Power Restrictions</p> <p>This unit is intended for connection to a TN power system and an IT power system of Norway only.</p>

3.1.2 Taiwan RoHS Declaration - Switch Systems

3.1.2.1 Restricted Substances Presence Condition (Declaration Table)

Equipment Name (設備名稱): 伺服器 (Server)

Unit (單元)	Lead (Pb) (鉛)	Mercury (Hg) (汞)	Cadmium (Cd) (鎘)	Hexavalent chromium (Cr+6) (六價鉻)	Polybrominated biphenyls (PBB) (多溴聯苯)	Polybrominated diphenyl ethers (PBDE) (多溴二苯醚)
印刷電路板 (Printed Circuit Board)	—	○	○	○	○	○
金屬外殼 (Metal Enclosure)	○	○	○	○	○	○
塑膠件 (Plastic Parts)	○	○	○	○	○	○
PCB 板電子零件 (PCB Electronic Components)	—	○	○	○	○	○

Notes

- **Note 1 (備考1):** “Exceeding 0.1 wt %” and “exceeding 0.01 wt %” indicate that the percentage content of the restricted substance exceeds the reference percentage value of presence condition.
- **Note 2 (備考2):** “○” indicates that the percentage content of the restricted substance does not exceed the percentage of reference value of presence.
- **Note 3 (備考3):** “—” indicates that the restricted substance corresponds to the exemption.

3.1.3 Taiwan RoHS Declaration - Gateway Systems

3.1.3.1 設備名稱 (Equipment Name)：閘道器 (Gateway)

單元 Unit	鉛 Lead (Pb)	汞 Mercury (Hg)	鎘 Cadmium (Cd)	六價鉻 Hexavalent chromium (Cr+6)	多溴聯苯 Polybrominated biphenyls (PBB)	多溴二苯醚 Polybrominated diphenyl ethers (PBDE)
印刷電路板 (Printed Circuit Board)	—	○	○	○	○	○
金屬外殼 (Metal Housing)	○	○	○	○	○	○
塑膠件 (Plastic Parts)	○	○	○	○	○	○
PCB 板電子零 件 (PCB Electronic Components)	—	○	○	○	○	○
備考 (Notes):						
1. "超出 0.1 wt %" 及 "超出 0.01 wt %" 係指限用物質之百分比含量超出百分比含量基準值。						
2. "○" 係指該項限用物質之百分比含量未超出百分比含量基準值。						
3. "—" 係指該項限用物質為排除項目。						

3.1.4 Taiwan BSMI Class A Statement - Warning to the User!

警告：為避免電磁干擾，本產品不應安裝或使用於住宅環境。

3.1.5 System Requirements

3.1.5.1 Hardware Requirements



Unless otherwise specified, NVIDIA Networking products are designed to work in an environmentally controlled data center with low levels of gaseous and dust (particulate) contamination.

The operating environment should meet severity level G1 as per ISA 71.04 for gaseous contamination and ISO 14644-1 class 8 for cleanliness level.

3.1.5.2 Airflow Requirements

NVIDIA MetroX-3 XC is offered with one airflow pattern: from the front panel to the rear panel. Please refer to the [Technical Specifications](#) section for airflow numbers

3.1.5.3 Software Requirements

See [Operating Systems](#) section under the Introduction section

3.1.6 Unpacking the Package

3.1.6.1 Safety Precautions

The NVIDIA MetroX-3 XC is installed in systems that operate with voltages that can be lethal. Before opening the case of the system, observe the following precautions to avoid injury and prevent damage to system components.

- Remove any metallic objects from your hands and wrists.
- Make sure to use only insulated tools.
- Verify that the system is powered off and is unplugged.
- Place the ESD mat on the floor where working and put on the ESD strap. Make sure the ESD strap is touching your skin and that the other end is connected to a verified ground.

3.1.6.2 Package Contents

Unpack the system, and make sure that all the parts have been sent against the parts list below. Check the parts for visible damage that may have occurred during shipping.

The appliance comes packed with the following items:

- 1X – bezel
- 1X – appliance
- 2X – installation rails, one right hand and one left hand
- 2X – power cable per PS unit (type C13-C14)
- 1X – Ethernet CAT6A cable (RJ45-to-RJ45), 2m

3.1.6.3 Installing the Appliance in Rack

1. Pull the inner rails out of the rack until they lock into place.



2. Locate the rear rail standoff on each side of the system and lower them into the rear J-slots on the slide assemblies.

3. Rotate the system downward until all the rail standoffs are seated in the J-slots.

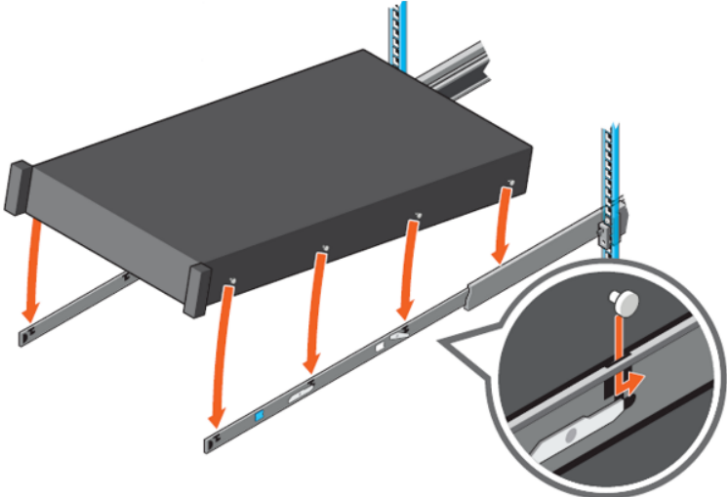

4. Push the system inward until the lock levers click into place.

5. Pull the blue side release lock tabs forward or backward on both rails and slide the system into the rack until the system is in the rack.

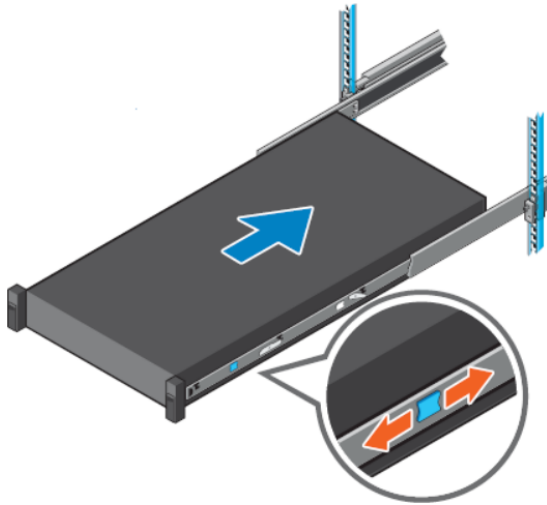

6. Ground the appliance (see "[Grounding the Appliance](#)").
7. Plug in the power cables (see "[Power Connections and Initial Power On](#)").
8. Push the ON/OFF button to start.



9. Check the Status LEDs and confirm that all of the LEDs show status lights consistent with normal operation.

! Any amber status LEDs are a cause for concern and must be dealt with immediately. It can take up to 5 minutes to boot up, during which time the status LED may indicate red.

! Rack Mount Instructions (similar rack-mount instructions are included with the installation instructions):

- Elevated Operating Ambient—If installed in a closed or multi-unit rack assembly, the operating ambient temperature of the rack environment may be greater than the room ambient. Therefore, consideration should be given to installing the equipment in an environment compatible with the maximum ambient temperature (T_{ma}) specified by the manufacturer.
- Reduced Air Flow— Installation of the equipment in a rack should be such that the amount of airflow required for the safe operation of the equipment is not compromised.

- Mechanical Loading—Mounting of the equipment in the rack should be such that a hazardous condition is not achieved due to uneven mechanical loading.
- Circuit Overloading—Consideration should be given to the connection of the equipment to the supply circuit and the effect that overloading of the circuits might have on overcurrent protection and supply wiring. Appropriate consideration of equipment nameplate ratings should be used when addressing this concern.
- Reliable Earthing—Reliable earthing of rack-mounted equipment should be maintained. Particular attention should be given to supply connections other than direct connections to the branch circuit (e.g., use of power strips).
- Please note that the handlebar and mounting ear must be installed after the slide rail kit has been installed completely.

3.2 Connecting the Appliance to the Network/Fabric

The appliance requires both InfiniBand and Ethernet (out-of band management) connectivity where eth0 should be connected to a management network switch, and both InfiniBand ports should be connected to InfiniBand switches. They can be connected to the same switch, but NVIDIA recommends connecting to two separate switches to ensure SM connectivity to the fabric.

3.3 Grounding the Appliance

Check to determine if your local or national electrical codes require an external ground to all IT components. If so, connect a ground wire to one of the casing screws and connect the other end to a valid ground. If you choose not to use the ground screw, make sure that the rack is properly grounded and that there is a valid ground connection between the chassis of the appliance and the rack. Test the ground using an Ohm meter.





Some national and/or local codes may require IT components to be bonded and externally grounded (not including the power cord ground). You must follow all national and local codes when installing this equipment.

3.4 Power Connections and Initial Power On

The system is shipped with two power supply units. Each unit has a separate AC receptacle. The system accepts input voltages of 100 - 127 VAC and 200 - 240 VAC for all possible PS units. The power cords should be standard 3-wire AC power cords including a safety ground and rated for 15A or higher. The power supplies deliver 750W AC.

 After inserting a power cable and turning the appliance on, confirm that the green system status LED light is on.

 When turning off the system, make sure both connector LEDs are off to ensure a powered down status.

 Do not hot swap the power supply if your appliance has only one power supply. You must power down the system to replace the power supply unit there is only one PS unit in the appliance.

Extracting and Inserting the Power Supply Unit

Two Power Inlets - Electric Caution Notifications

CAUTION	ACHTUNG	ATTENTION
Risk of electric shock and energy hazard. The two PS units are independent.	Gefahr des elektrischen Schocks. Entfernen des Netzsteckers elnes	Risque de choc et de danger e'lectriques. Le de'branchement d'une seule alimentation stabilise'e ne de'branch
Disconnect all power supplies to ensure a powered down state inside of the UFM-	Netzteils spannungsfrei. Um alle Einhieten spannungsfrei zu machen sind die Netzstecker aller Netzteile zu	uniquement qu'un module "Alimentation Stabilise'e". Pour isoler completement le module en cause, Il faut de'brancher toutes les ali-

 The power supply is only hot-swappable if you have a redundant system with two power supplies installed. If you only have one power supply installed, before removing or replacing the power supply, you must first:

1. Make sure the system is out of service.
2. Turn off all peripheral devices connected to the system.
3. Turn the system off by pressing the power button.
4. Unplug the AC power cord from the system or wall outlet.

To replace the power supply, follow these steps:

1. Disconnect the power cable from the power outlet and from the PSU you intend to remove.

2. Remove the cable from the strap on the PSU handle.
3. Unlatch and lift the optional cable management arm if it interferes with the PSU removal.
4. Press and hold the PSU latch while sliding the PSU out:





5. Slide the new PSU in:



6. If you have unlatched the cable management arm, re-latch it.
7. Connect the power cable to the PSU and plug the cable into a power outlet.

 When connecting the power cable to the PSU, secure the cable to the PSU with the strap.

 When installing, hot swapping or hot adding a new PSU, wait 15 seconds for the system to recognize the PSU and determine its status. PSU redundancy may not occur until discovery is complete. The PSU status indicator turns green to indicate that the PSU is functioning properly.

 Do not run the system with openings of missing parts. This may cause overheating due to improper air flow.

3.5 Replacing the SSD

 Never pull out a working hard drive while the appliance is turned on. You can safely pull out a faulty hard drive indicated by a solid amber light.

If one SSD physically fails, the appliance keeps working thanks to RAID mirroring. You can pull out and replace a faulty drive with a new blank SSD. The blank SSD will synchronize with the other SSD. This takes up to 48 hours but does not interrupt appliance operation.

1. Power down the appliance before removing the SSD
2. Press the release button to open the drive carrier release handle.
3. Holding the drive carrier release handle, slide the drive carrier out of the drive slot.
4. Remove the SSD from its carrier drawer.



5. Hold the release handle and slide the drive carrier into the drive slot.

6. Close the drive carrier release handle to lock the drive in place.



7. Power on the appliance.

! The SW RAID mechanism will identify that a new SSD was inserted and synchronize the data with the second SSD, this process might take up to 48 hours to complete.

3.6 Disassembly of the System from the Rack

To disassemble the appliance from the rack:

1. Shut down the system.
2. Unplug and remove all connectors.
3. Unplug all power cords.
4. Remove the ground wire.
5. Unscrew the 2 center bolts from inside the handles.
6. Slide the appliance from the rack.
7. Remove the rail slides from the rack.

3.7 Removing the Battery

! NVIDIA does not support battery replacement. Customer removal of the cover will void the warranty. Remove the cover only to comply with WEEE directives or to disassemble the appliance for environmentally approved disposal.

This procedure is only to be used when you are disassembling this appliance before discarding, to comply with regulations regarding disposal of batteries.

1. Remove the cover.
2. Remove the battery and dispose of it according to local, state and federal regulations.

3.8 Disposal



According to the WEEE Directive 2002/96/EC, all waste electrical and electronic equipment (EEE) should be collected separately and not disposed of with regular household waste. Dispose of this product and all of its parts in a responsible and environmentally friendly way.

3.9 Cable Installation

3.9.1 Power Cable

The NVIDIA MetroX-3 XC appliance is shipped with two power supply units. Each unit has a separate AC receptacle. The appliance accepts voltages of 100-127 VAC and 200-240 VAC for all possible power supply units. The power cords should be a standard 3-wire AC power cards, including a safety ground, and rated for 15A or higher. The power supplies deliver 2KW AC.



After inserting a power cable and turning the appliance on, confirm the green system LED light is on.



Do not hot swap the power supply if your appliance has only one power supply. Instead, power down the system to replace the power supply unit.

3.9.2 ConnectX-7 Networking Cards Cables

Networking Cable Installation

All cables can be inserted or removed with the unit powered on. To insert a cable, press the connector into the port receptacle until the connector is firmly seated.

1. Support the weight of the cable before connecting the cable to the adapter card. Do this by using a cable holder or tying the cable to the rack.
2. Determine the correct orientation of the connector to the card before inserting the connector. Do not try and insert the connector upside down. This may damage the adapter card.
3. Insert the connector into the adapter card. Be careful to insert the connector straight into the cage. Do not apply any torque, up or down, to the connector cage in the adapter card.
4. Make sure that the connector locks in place.



When installing cables, make sure that the latches engage.



Always install and remove cables by pushing or pulling the cable and connector in a straight line with the card.

1. After inserting a cable into a port, the green LED indicator will light when the physical connection is established (that is, when the unit is powered on and a cable is plugged into the port with the other end of the connector plugged into a functioning port). See [Network Interface Cards LEDs](#) under the Interfaces section.
2. After plugging in a cable, lock the connector using the latching mechanism particular to the cable vendor. When data is being transferred, the green LED will blink.
3. Care should be taken to not impede the air exhaust flow through the ventilation holes. Use cable lengths that allow for routing horizontally around to the side of the chassis before bending upward or downward in the rack.
4. To remove a cable, disengage the locks and slowly pull the connector away from the port receptacle. The LED indicator will turn off when the cable is unseated.

All cables can be inserted or removed with the unit powered on. To insert a cable, press the connector into the port receptacle until the connector is firmly seated. The LED indicator, corresponding to each data port, will light up when the physical connection is established. When a logical connection is made, the relevant port LED will turn on. To remove a cable, disengage the locks and slowly pull the connector away from the port receptacle. The LED indicator for that port will turn off when the cable is unseated. For full cabling guidelines, ask your NVIDIA Networking representative for a copy of NVIDIA Cable Management Guidelines and FAQs Application Note.



Do not force the cable into the cage with more than 40 newtons/9.0 pounds/4kg of force. Greater insertion force may cause damage to the cable or to the cage.

3.10 Initial Power-On

The system's input voltage is specified in the [Technical Specifications](#) chapter. The power cords should be a standard 3-wire AC power cords including a safety ground and rated for 15A or higher.

- ✘ The system platform will automatically power on when AC power is applied. There is no power system. Check all boards, power supplies and fans for proper insertion before plugging in a power cable.

Step 1. Plug in the first power cable.

Step 2. Plug in the second power cable.

Step 3. Wait for the System Status LED to turn green.

- ✘ It may take up to five minutes to turn on the system. If the System Status LED is red after five minutes, unplug the system and call your NVIDIA Networking representative for assistance.

Step 4. Check the System Status LEDs and confirm that all of the LEDs show status lights consistent with normal operation (initially flashing, and then moving to a steady color). For more information, refer to [System Monitoring](#).

- ✘ After inserting a power cable and confirming the green System Status LED light is on, make sure that the Fan Status LED is green. If the Fan Status LED is not green, unplug the power connection, and check that the fan module is inserted properly and that the mating connector of the fan unit is free of any dirt and/or obstacles. If no obstacles were found and the problem persists, call your NVIDIA Networking representative for assistance.

3.11 System Maintenance

This chapter contains the installations and Un-installation instructions of the following customer replaceable units:

3.11.1 Power Supply Units

MetroX-3 XC is equipped with two replaceable power supply units that work in a redundant configuration. The below figure shows the power side of the system which includes a hot-swap power supply unit (PSU).

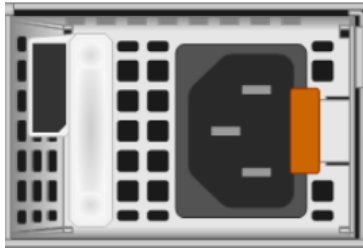

3.11.1.1 Extracting and Inserting the Power Supply Unit

⚠ The power supply is only hot-swappable if you have a redundant system with two power supplies installed. If you only have one power supply installed, before removing or replacing the power supply, you must first take the appliance out of service, turn off all peripheral devices connected to the system, turn off the system by pressing the power button, and unplug the AC power cord from the system or wall outlet.

The power supply can be replaced in case it fails.

➤ To extract a power supply unit:

Step 1. If a filler panel is installed, remove the filler panel.

Step 2. If a power supply is installed, grab the handle with your thumb pointing toward the latch. Push the latch with your thumb towards the handle while you pull the power supply out of the appliance.

➤ To insert a power supply unit:

Step 1. Make sure the mating connector of the new unit is free of any dirt and/or obstacles.

✘ Do not run the appliance with openings due to missing parts. This may cause overheating due to improper airflow.

Step 2. Insert the power supply unit by sliding it into the opening, until a slight resistance is felt.

Step 3. Continue pressing the power supply unit until it seats completely. The latch will snap into place, confirming the proper installation.

Step 4. Insert the power cord into the supply connector.

Step 5. Insert the other end of the power cord into an outlet of the correct voltage.

4 Configuring the Gateway for the First Time

4.1 MetroX Initialization

To initialize the gateway, follow the steps below.

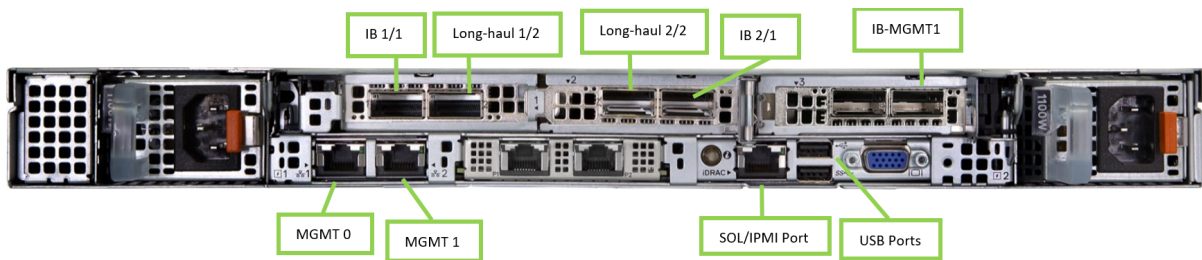

1. Enable remote access to serial console via IPMI.

 The MAC address for the SOL port can be found in the BIOS or on the outside of the chassis is labeled with the port MAC address.

- a. Connect a VGA monitor and USB keyboard directly to the appliance.
- b. To enter the BIOS, reboot the appliance and press <F2> on the screen below to enter BIOS setup.

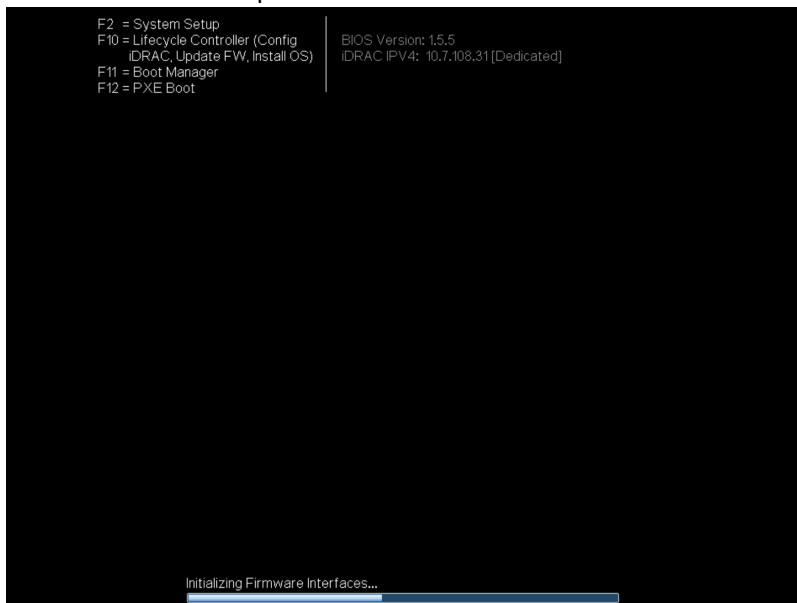

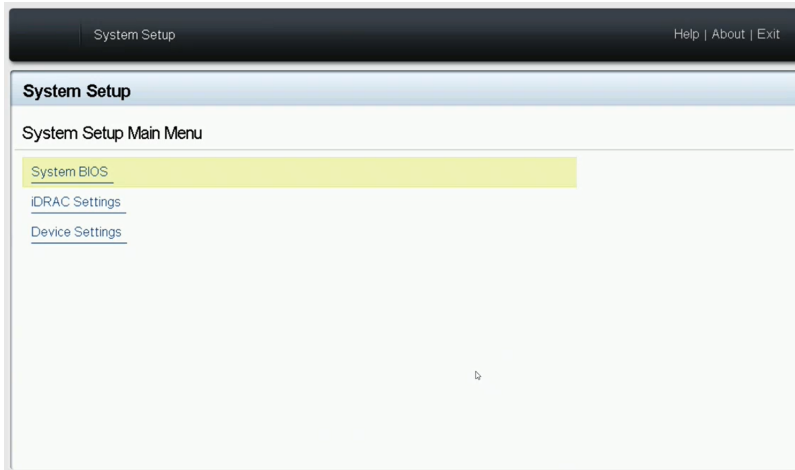

- c. Go to “iDRAC Settings” tab → “Network”
- d. Here the MAC can be found and various network configuration related to the SOL port. its IPV4 settings can also be viewed and configured (by default it will try to get IP via DHCP).

 any changes to the IPV4 settings would only take affect after a reboot

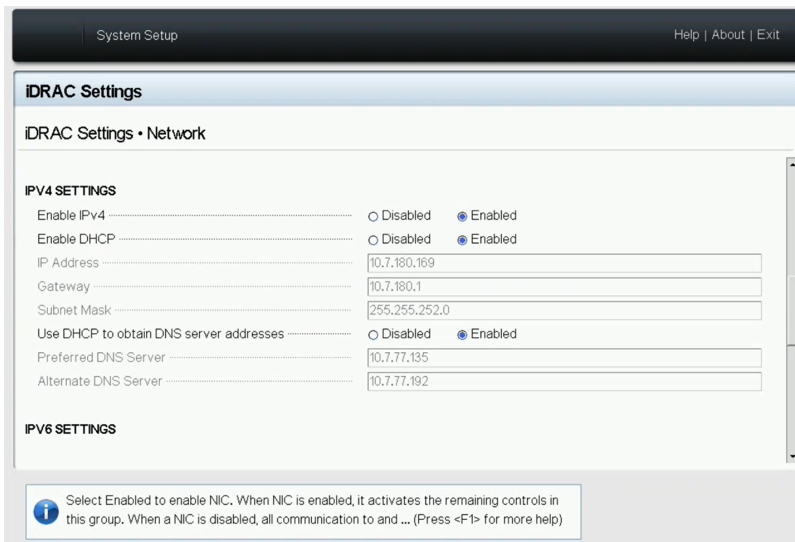

at the bottom of the screen above, make sure "Enable IPMI over LAN" is



- e. Go back to main BIOS menu shown in step b (press esc and follow prompts), go to "System BIOS" tab → "Boot Settings" and make sure "boot Mode" is

"UEFI"

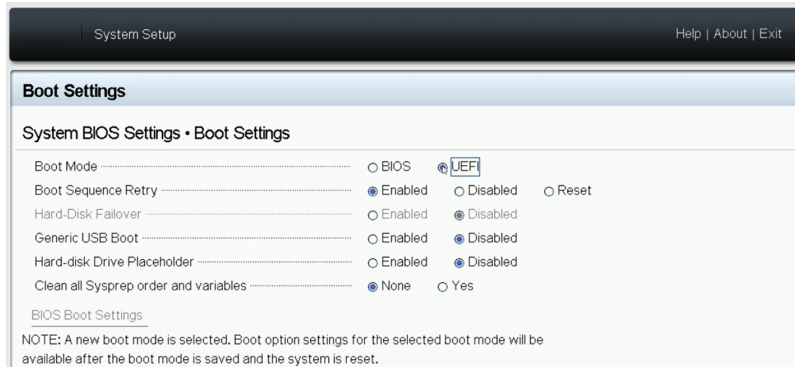

- f. Go back to previous screen ("System BIOS"), go to "Serial Communication" tab and make sure "Serial communication" field is "On with Console Redirection"
- g. Exit the BIOS and save changes. the appliance will now reboot and can be accessible through the IPMI tool
- h. The serial console can now be Accessed remotely by following IPMI command (user and password should be "admin" by default).

```
ipmitool -I lanplus -H <IPMI_CONTROLLER_IP> -U <user> -P <password> sol activate
```

Example:

```
ipmitool -I lanplus -H 10.7.113.60 -U admin -P admin sol activate
```



Make sure to connect to the console SOL port of the metroX and not to the management port.



Once operating system boots, iKVM over HTML5 no longer shows any output. However, iKVM over HTML5 can be used for BIOS configurations at the very beginning of the system boot sequence right before the operating system boots.

2. Log in as admin and use admin as password, using IPMI tool.

```
ipmitool -I lanplus -H <IP Address> -U admin -P admin sol activate
```



Only a single serial connection via the IPMI can exist at any point, another connection attempt while the IPMI is in use will result in the error.

```
Info: SOL payload already active on another session
```

To forcibly disconnect the existing connection, use the following command:

```
ipmitool -I lanplus -H <IP Address> -U admin -P admin sol deactivate
```

3. Connect the management Ethernet cable to mgmt0 port on the back panel of the appliance.
4. Go through the MetroX Management configuration wizard (Using the IPMI connection from step 2)

Wizard Session Display (Example)	Comments
Do you want to use the wizard for initial configuration? yes	This configuration must be performed the first time the MetroX is operated or after resetting it to the factory defaults. Type "y" and then press <Enter>.
Step 1: Hostname? [MetroX3xc-1]	To accept the default hostname, press <Enter>. Otherwise, type a different hostname and press <Enter>.
Step 2: Use DHCP on mgmt0 interface? [yes]	Perform this step to obtain an IP address for the MetroX (mgmt0 is the management port of the MetroX). <ul style="list-style-type: none"> • Typing "yes" will have the DHCP server assign the IP address • Typing "no" (no DHCP) will offer the use of the "zeroconf" configuration or not. For the use of Zeroconf, type "yes" and the session will continue. If "no" (no Zeroconf) is typed, enter a static IP and the session will continue.
Step 3: Enable IPv6 [yes]	Perform this step to enable IPv6 on management ports. <ul style="list-style-type: none"> • Type "yes" to enable enable IPv6. • Type "no" to not enable IPv6 (Step 4 will be skipped)
Step 4: Enable IPv6 autoconfig (SLAAC) on mgmt0 interface	Perform this step to enable StateLess address autoconfig on external management port. <ul style="list-style-type: none"> • Type "yes" to enable • Type "no" to disable
Step 5: Use DHCPv6 on mgmt0 interface? [yes]	Perform this step to enable DHCPv6 on the MGMT0 interface.
Step 6: Enable password hardening?	Perform this step to enable/disable password hardening on your machine. If enabled, new passwords will be checked upon configured restrictions. If you wish to enable it, type "yes" and press . If you wish to disable it, enter "no"

Wizard Session Display (Example)	Comments
Step 7: Admin password (Must be typed)? <new_password>	To avoid illegal access to the machine, type a password and press <Enter>. An admin password must be entered upon initial configuration. Due to California Senate Bill No. 327, this stage is required and cannot be skipped.
Step 8: Confirm admin password? <new_password>	Confirm the password by re-entering it. Note that password characters are not printed.
Step 9: Monitor password (Must be typed)? <new_password>	To avoid illegal access to the machine, please type a password and then press <Enter>. An admin password must be entered upon initial configuration. Due to California Senate Bill No. 327, this stage is required and cannot be skipped.
Step 10: Confirm monitor password? <new_password>	Confirm the password by re-entering it. Note that password characters are not printed.
You have entered the following information: Hostname: <metroX name> Use DHCP on mgmt0 interface: yes Enable IPv6: yes Enable IPv6 autoconfig (SLAAC) on mgmt0 interface: yes Enable DHCPv6 on mgmt0 interface: no Enable password hardening: yes Admin password (Enter to leave unchanged): (CHANGED) To change an answer, enter the step number to return to. Otherwise hit <enter> to save changes and exit. Choice: <Enter> Configuration changes saved. To return to the wizard from the CLI, enter the "configuration jump-start" command from configuration mode. Launching CLI... <metroX name> [standalone: master] >	The wizard displays a summary of choices and then asks to confirm the choices or to re-edit them. <ul style="list-style-type: none"> • Press <Enter>, to save changes and exit • Enter the relevant configuration step number, to edit any of the choices To run the command "configuration jump-start", Config mode must be used.

4.1.1 Rerunning the Wizard

To rerun the wizard, do the following:

- a. Enter config mode.

```
NVDA-OS-XC > enable
NVDA-OS-XC # config terminal
```

- b. Rerun the wizard.

```
NVDA-OS-XC (config) # configuration jump-start
```

5. Check the mgmt0 interface configuration before attempting a remote connection (e.g., SSH) to the appliance. Specifically, verify the existence of an IP address.

```
NVDA-OS-XC (config) # show interfaces mgmt0
```

```
Interface mgmt0 status:
Comment           :
Admin up          : yes
Link up           : yes
DHCP running      : yes
IP address        : 10.7.148.61
Netmask           : 255.255.0.0
IPv6 enabled      : yes
Autoconf enabled: no
Autoconf route   : yes
Autoconf privacy: no
DHCPv6 running   : no
IPv6 addresses   : 1

IPv6 address:
fe80::268a:7ff:fe53:3d8e/64

Speed             : 1000Mb/s (auto)
Duplex            : full (auto)
Interface type    : ethernet
Interface source  : physical
MTU               : 1500
HW address        : 00:02:c9:11:a1:b2

Rx:
 11700449 bytes
  55753 packets
    0 mcast packets
    0 discards
    0 errors
    0 overruns
    0 frame

Tx:
 5139846 bytes
 28452 packets
    0 discards
    0 errors
    0 overruns
    0 carrier
    0 collisions
 1000 queue len
```

4.1.2 Starting the Command Line Interface (CLI)

1. Set up an Ethernet connection between the metroX and a local network machine using a standard SOL connector.
2. Start a remote secured shell (SSH) to the metroX using the command “ssh -l <username> <metroX ip address>”.

```
rem_mach1 > ssh -l <username> <ip address>
```

3. Log in to the metroX (default username and password are both "admin").
4. Read and accept the EULA, when prompted.
5. Once the following prompt appears, the system is ready to use.

```
Mellanox metroX
Password:
Last login: <time> from <ip-address>

metroX >
```



If firmware was upgraded, firmware boot bar will appear and the CLI will be blocked until firmware upgrade is complete.

```
metrox3-xc-fd9d4c login: admin
Password:
Number of total successful connections since last 1 days: 0

NVIDIA MetroX3-XC

  System is initializing!
  This may take a few minutes



  FW burning:

  30.0% [#####]
  #
```

5 System Monitoring

Front Panel Monitoring Interfaces

5.1 Right Control Panel





Index	Indicator or Button	Icon	Description
1	Power button		<p>Indicates if the system is powered on or off. Press the power button to manually power on or off the system.</p> <div style="border: 1px solid orange; padding: 5px;"><p> Press the power button to shut down the ACPI-compliant operating system.</p></div> <p>For a graceful shutdown of the system, use the relevant CLI command. To force a shutdown of the appliance, hold the button down until the appliance turns off. The LED of the button displays the system's power status.</p>

5.2 Left Control Panel View

Index	Indicator or Button	Icon	Description
1	System health and system ID indicator		Indicates the system health
2	System status LEDs	See System Status LEDs below	Indicates the status of the system

5.2.1 System Status LEDs

The system status indicators are located on the front left-side panel.

Icon	Description	Condition	Corrective Action
	Drive indicator	The indicator turns solid amber if there is a drive error	<ul style="list-style-type: none"> • Check the System Event Log to determine if the drive has an error. • Run the appropriate Online Diagnostics test. Restart the system and run embedded diagnostics (ePSA). • If the drives are configured in a RAID array, restart the system, and enter the host adapter configuration utility program.
	Temperature indicator	The indicator turns solid amber if the system experiences a thermal error (for example, the ambient temperature is out of range or there is a fan failure)	<p>Ensure that none of the following conditions exist:</p> <ul style="list-style-type: none"> • A cooling fan has been removed or has failed. • System cover, air shrouds, or back filler bracket has been removed. • Ambient temperature is too high. • External airflow is obstructed.
	Electrical indicator	The indicator turns solid amber if the system experiences an electrical error (for example, voltage out of range, or a failed power supply unit (PSU) or voltage regulator)	Check the System Event Log or system messages for the specific issue. If it is due to a problem with the PSU, check the LED on the PSU. Reseat the PSU.
	Memory indicator	The indicator turns solid amber if a memory error occurs	Check the System Event Log or system messages for the location of the failed memory. Reseat the memory module.
	PCIe indicator	The indicator turns solid amber if a PCIe card experiences an error	Restart the system. Update any required drivers for the PCIe card. Reinstall the card.

5.2.2 System Health and System ID Indicator Codes

The system health and system ID indicator is located on the left control panel of the system.

System Health and System ID Indicator Code	Condition
Solid blue	Indicates that the system is powered on and healthy, and that system ID mode is not active. Press the system health and system ID button () to switch to system ID mode.
Blinking blue	Indicates that the system ID mode is active. Press the system health and system ID button to switch to system health mode.
Solid amber	Indicates that the system is in fail-safe mode.
Blinking amber	Indicates that the system is experiencing a fault. Check the System Event Log for specific error messages.

5.3 SSD LED Indicators

The LEDs on the drive carrier indicate the state of each drive. Each drive carrier has two LEDs: an activity LED (green) and a status LED (bicolor, green/amber). The activity LED blinks whenever the drive is accessed.

SSD Indicators

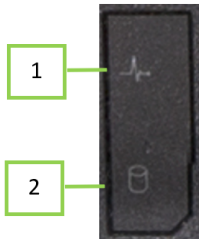

Index	Description
1	Drive status LED indicator
2	Drive activity LED indicator

The following table lists the drive indicator codes:

Drive Status Indicator Code	Condition
Blinks green twice per second	Indicates that the drive is being identified or preparing for removal
Off	Indicates that the drive is ready for removal <div style="border: 1px solid orange; padding: 5px; margin-top: 5px;"> <p> The drive status indicator remains off until all drives are initialized after the system is powered on. Drives are not ready for removal during this time.</p> </div>
Blinks green, amber, and then powers off	Indicates that there is an unexpected drive failure
Blinks amber four times per second	Indicates that the drive has failed
Blinks green slowly	Indicates that the drive is rebuilding
Solid green	Indicates that the drive is online
Blinks green for three seconds, amber for three seconds, and then powers off after six seconds	Indicates that the rebuild has stopped

5.4 Rear Panel Monitoring Interfaces

5.4.1 RJ-45 Remote Management Port

The remote management port is designed for secure local and remote server management and helps IT administrators deploy, update, and monitor the NVIDIA® MetroX-3 XC Appliance.



5.4.2 RJ-45 Management Ports eth0-eth1

These four RJ-45 ports are found on the rear side of the appliance. The eth0-eth1 and remote management interfaces are pre-configured as DHCP and the initial host name is MetroX3xc-1 (the MAC address appears on the pull-tab label), so their IP addresses can be obtained from the DHCP server. If no DHCP server is available, you have to use a serial cable to connect and configure eth0 and remote-management IP addresses with a static IP address.



Configuring the appliance via the serial port is required only in the case where out-of-the-box DHCP configuration for eth0 cannot be used. (There is no DHCP server in the management network). The user is then required to use the serial port to configure a static IP on eth0.



NIC#1 Ethernet connector gets connected to Ethernet switches. This switch must be configured to 100M/1G auto-negotiation.

5.4.3 ConnectX-7 OSFP Ports

These 2 OSFP ports are found on the rear side of the appliance. They should be connected to an IB switch in the fabric. It is recommended to connect to two different switches for redundancy. The appliance can be connected only to a single IB fabric.

5.4.4 RJ-45 Ethernet Connector for Remote Management

The appliance has several Ethernet management interfaces. The primary management interface is eth0. An additional interface exists, for connecting to a remote management controller (it usually connects to the same management network as eth0).

To use out-of-the-box DHCP settings, the default hostname for the appliance (over eth0) is "MetroX3xc-1". The MAC address for eth0 is available on the pull-tab and can be configured in the DHCP server.

To use the remote management controller with DHCP, the free-range IP allocation must be enabled on the DHCP server. A static IP address for remote management interface can be configured via the CLI (`chassis remote-management ip` command).

 Configuration via a serial port is only required if you want to use a static IP address and not the out-of-the-box DHCP setting for eth0. Otherwise, an IP is assigned by the DHCP server, and you can log into the CLI over LAN.

 NIC#1 Ethernet connector gets connected to Ethernet switches. This switch must be configured to 100M/1G auto-negotiation.

5.4.5 USB Interface

There are two USB connectors. These connectors can be used to install software and/or firmware upgrades using a memory device that has a USB connector. This connector is USB 2.0 compliant. Various upload/download operations are also supported through the USB using the CLI.



5.4.6 PSU Status Indicators

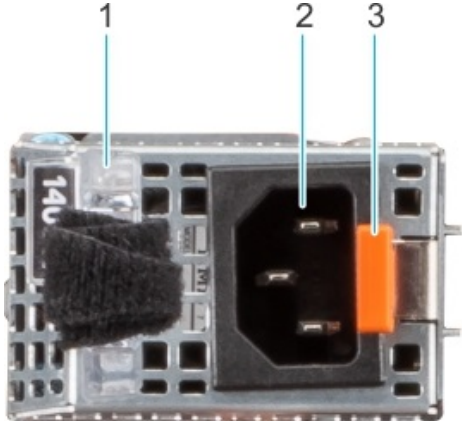

Index	Description
1	AC PSU handle
2	Socket
3	Release latch

Each power supply (PS) unit has a one built-in fan and a single two-color LED on the right side of the PS unit that indicates the internal status of the unit.

The following table presents the AC PSU status indicator codes:

Power Indicator Codes	Condition
Green	Indicates that a valid power source is connected to the PSU and the PSU is operational
Blinking amber	Indicates an issue with the PSU
Not powered on	Indicates that the power is not connected to the PSU
Blinking green	Indicates that the firmware of the PSU is being updated <div style="border: 1px solid red; padding: 5px; margin-top: 5px;"> ✘ Do not disconnect the power cord or unplug the PSU when updating firmware. If firmware update is interrupted, the PSUs will not function. </div>

Power Indicator Codes	Condition
Blinking green and powers off	<p>When hot-plugging a PSU, it blinks green five times at a rate of 4 Hz and powers off. This indicates a PSU mismatch due to efficiency, feature set, health status, or supported voltage.</p> <div style="border: 1px solid red; padding: 5px; margin-bottom: 5px;"> <p>✘ If two PSUs are used, they must be of the same type and have the same maximum output power.</p> </div> <div style="border: 1px solid red; padding: 5px; margin-bottom: 5px;"> <p>✘ When correcting a PSU mismatch, replace the PSU with the blinking indicator. Swapping the PSU to make a matched pair can result in an error condition and an unexpected system shutdown. To change from a high output configuration to a low output configuration or vice versa, you must power off the system.</p> </div> <div style="border: 1px solid red; padding: 5px;"> <p>✘ When two identical PSUs receive different input voltages, they can output different wattage, and trigger a mismatch.</p> </div>

The following table presents the DC PSU status indicator codes:

Power Indicator Codes	Condition
Green	Indicates that a valid power source is connected to the PSU, and the PSU is operational
Blinking amber	Indicates an issue with the PSU
Not powered on	Indicates that the power is not connected to the PSU
Blinking green	When hot-plugging a PSU, it blinks green five times at a rate of 4 Hz and powers off. This indicates a PSU mismatch due to efficiency, feature set, health status, or supported voltage.

5.4.7 NIC Activity LED Indicators

Each NIC on the back of the system has indicators that provide information about the activity and link status. The activity LED indicator indicates if data is flowing through the NIC, and the link LED indicator indicates the speed of the connected network.

NIC Activity LEDs

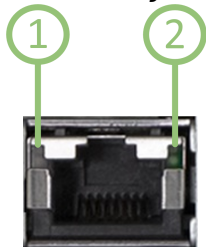

Index	Description
1	Link LED indicator
2	Activity LED indicator

The following table lists the drive indicator codes:

NIC Indicator Code	Condition
Link and activity indicators are off	Indicates that the NIC is not connected to the network
Link indicator is green, and activity indicator is blinking green	Indicates that the NIC is connected to a valid network at its maximum port speed, and data is being sent or received
Link indicator is amber, and activity indicator is blinking green	Indicates that the NIC is connected to a valid network at less than its maximum port speed, and data is being sent or received
Link indicator is green, and activity indicator is off	Indicates that the NIC is connected to a valid network at its maximum port speed, and data is not being sent or received
Link indicator is amber, and activity indicator is off	Indicates that the NIC is connected to a valid network at less than its maximum port speed, and data is not being sent or received
Link indicator is blinking green, and activity is off	Indicates that the NIC identity is enabled through the NIC configuration utility

5.5 Air Flow

The appliance comes with a single air flow pattern; a front (hard-drive) side to back (power-supply) side.

6 Troubleshooting

As soon as the appliance is plugged in, make sure that the green power LEDs on the power supply units are on.

6.1 General Troubleshooting

Issue	Resolution
System Status LED is RED	Unplug the appliance and call your NVIDIA representative.
Power Supply Unit Status LED is not lit or is RED	<ol style="list-style-type: none">1. Check that the power cable is plugged into a working outlet.2. Check that the power cable has a voltage within the range of 100 - 240 volts AC.3. Remove and reinstall the power cable.4. Remove and reinstall the power supply unit.
The Power Button w/ Integrated LED for the appliance shuts off	<ol style="list-style-type: none">1. Check that there is adequate ventilation.2. Make sure that there is nothing blocking the front or rear of the chassis and that the fan modules and ventilation holes are not blocked (especially dust over the holes).3. If you find dust blocking the holes it is recommended to clean the fan unit and remove the dust from the front and rear panels of the appliance using a vacuum cleaner.
The activity LEDs do not come on	Check if the appliance has been started.
The appliance is off	<ol style="list-style-type: none">1. Press the Power Button w/Integrated LED If that does not work:2. Unplug the appliance.3. Wait 5 minutes.4. Plug in the appliance, and press the Power Button w/Integrated LED.5. If the appliance does not come on, check the power supplies.6. If the appliance comes on, use the management software to determine the cause of the shutdown.7. Check the temperature.8. Check the Fan status.

7 Technical Specifications

7.1 MTQ8400 Specifications

Physical	Dimensions (HxWxD): 1.7" x 18.97" x 31.85" 42.8mm x 482mm x 809mm (822.84 mm/32.39" including bezel)		
	Weight: 17kg		
	Mounting: 19" Rack mount		
Protocol Support	InfiniBand: IBTA v1.5 ^a Auto-Negotiation: NDR200 (2 lanes x 100Gb/s per lane) port, HDR (50Gb/s per lane) port, HDR100 (2 lane x 50Gb/s per lane), EDR (25Gb/s per lane) port, FDR (14.0625Gb/s per lane), 1X/2X/4X SDR (2.5Gb/s per lane)		
	Ethernet Protocols: 200GAUI-4 C2M, 200GBASE-CR4, 100GAUI-2 C2M, 100GBASE-CR4, 100GBASE-CR, 100GBASE-CR1, 50GAUI-2 C2M, 50GAUI-1 C2M, 50GBASE-CR, 50GBASE-R2, 40GBASE-CR4, 40GBASE-R2, 25GBASE-R, 10GBASE-R, 10GBASE-CX4, 1000BASE-CX, CAUI-4 C2M, 25GAUI C2M, XLAUI C2M, XLPPI, SFI		
	Data Rate	InfiniBand	SDR/DDR/QDR/EDR/HDR100/HDR/NDR200
		Ethernet	1/25/50/100/200 Gb/s
	Gen3: SERDES @ 8.0GT/s, x16 lanes (2.0 and 1.1 compatible)		
Power	Input Voltage: 1100W power supply module 100-240 V at 50/60 Hz 12-6.3 A		
	CPU: 2x Intel Xeon Gold 6336Y/2.4GHz/36 MB/24 Cores/48 Threads 185W TDP		
	PSU: 80 Plus Titanium 1+1 redundant power supply 1100 W @ 100-240 V		
	Maximum: 689W		
Environmental	Temperature	Operating	0 to 35°C
		Non-Operating	-20 to 60°C
	Humidity	Operating Relative Humidity	10~85% @ 40°C (non-condensing)
		Non-operating Relative Humidity	10~95% @ 40°C (non-condensing)
	Vibration (5 ~ 500 Hz)	0.25 Grms	
	Shock	10G (with 11ms duration, half sine wave)	
	Thermal	Airflow	52.1 CFM
Maximum heat dissipation		2241.8 BTU/hr	

Reliability, Availability and Serviceability Features	Hot-swapability/ Redundancy	Hot-swappable: 1+1 power supplies N+N redundant
--	------------------------------------	--

^a The ConnectX-7 adapters supplement the IBTA auto-negotiation specification to get better bit error rates and longer cable reaches. This supplemental feature only initiates when connected to another NVIDIA InfiniBand product.

7.2 Thermal Threshold Definitions

There are two thermal threshold definitions for MetroX-3 XC which impact the overall system operation state:

- **Critical** – When the device crosses this temperature, the firmware will automatically shut down the device. This temperature threshold is set from the BIOS (Advanced > IT8528 HW Monitor > CPU ACPI Shutdown Temperature). The temperature threshold can be configured from 50-110°C.
- **Emergency** – The temperature threshold is set by the CPU's internal thermal trip. It is impossible to change the temperature value through a software interface.

8 Inventory Information

The system's inventory parameters (such as Serial Number and Part Number) are found on the pull-tab label. The pull-tab can be extracted from the right bottom side of the system's front panel.



9 Field Replaceable Units

Ordering Number	Part Description
MTQ84-PS	NVIDIA power supply for MetroX-3 XC appliance
MTQ84-RKIT	NVIDIA rail kit for MetroX-3 XC appliance
TQ8400-SD	NVIDIA MetroX-3 XC appliance SSD FRU

10 Revision History

Date	Revision	Description of Changes
January 2023	1.0	First Release

Notice

This document is provided for information purposes only and shall not be regarded as a warranty of a certain functionality, condition, or quality of a product. Neither NVIDIA Corporation nor any of its direct or indirect subsidiaries and affiliates (collectively: "NVIDIA") make any representations or warranties, expressed or implied, as to the accuracy or completeness of the information contained in this document and assumes no responsibility for any errors contained herein. NVIDIA shall have no liability for the consequences or use of such information or for any infringement of patents or other rights of third parties that may result from its use. This document is not a commitment to develop, release, or deliver any Material (defined below), code, or functionality.

NVIDIA reserves the right to make corrections, modifications, enhancements, improvements, and any other changes to this document, at any time without notice. Customer should obtain the latest relevant information before placing orders and should verify that such information is current and complete.

NVIDIA products are sold subject to the NVIDIA standard terms and conditions of sale supplied at the time of order acknowledgement, unless otherwise agreed in an individual sales agreement signed by authorized representatives of NVIDIA and customer ("Terms of Sale"). NVIDIA hereby expressly objects to applying any customer general terms and conditions with regards to the purchase of the NVIDIA product referenced in this document. No contractual obligations are formed either directly or indirectly by this document.

NVIDIA products are not designed, authorized, or warranted to be suitable for use in medical, military, aircraft, space, or life support equipment, nor in applications where failure or malfunction of the NVIDIA product can reasonably be expected to result in personal injury, death, or property or environmental damage. NVIDIA accepts no liability for inclusion and/or use of NVIDIA products in such equipment or applications and therefore such inclusion and/or use is at customer's own risk.

NVIDIA makes no representation or warranty that products based on this document will be suitable for any specified use. Testing of all parameters of each product is not necessarily performed by NVIDIA. It is customer's sole responsibility to evaluate and determine the applicability of any information contained in this document, ensure the product is suitable and fit for the application planned by customer, and perform the necessary testing for the application in order to avoid a default of the application or the product.

Weaknesses in customer's product designs may affect the quality and reliability of the NVIDIA product and may result in additional or different conditions and/or requirements beyond those contained in this document. NVIDIA accepts no liability related to any default, damage, costs, or problem which may be based on or attributable to: (i) the use of the NVIDIA product in any manner that is contrary to this document or (ii) customer product designs.

No license, either expressed or implied, is granted under any NVIDIA patent right, copyright, or other NVIDIA intellectual property right under this document. Information published by NVIDIA regarding third-party products or services does not constitute a license from NVIDIA to use such products or services or a warranty or endorsement thereof. Use of such information may require a license from a third party under the patents or other intellectual property rights of the third party, or a license from NVIDIA under the patents or other intellectual property rights of NVIDIA.

Reproduction of information in this document is permissible only if approved in advance by NVIDIA in writing, reproduced without alteration and in full compliance with all applicable export laws and regulations, and accompanied by all associated conditions, limitations, and notices.

THIS DOCUMENT AND ALL NVIDIA DESIGN SPECIFICATIONS, REFERENCE BOARDS, FILES, DRAWINGS, DIAGNOSTICS, LISTS, AND OTHER DOCUMENTS (TOGETHER AND SEPARATELY, "MATERIALS") ARE BEING PROVIDED "AS IS." NVIDIA MAKES NO WARRANTIES, EXPRESSED, IMPLIED, STATUTORY, OR OTHERWISE WITH RESPECT TO THE MATERIALS, AND EXPRESSLY DISCLAIMS ALL IMPLIED WARRANTIES OF NONINFRINGEMENT, MERCHANTABILITY, AND FITNESS FOR A PARTICULAR PURPOSE. TO THE EXTENT



NOT PROHIBITED BY LAW, IN NO EVENT WILL NVIDIA BE LIABLE FOR ANY DAMAGES, INCLUDING WITHOUT LIMITATION ANY DIRECT, INDIRECT, SPECIAL, INCIDENTAL, PUNITIVE, OR CONSEQUENTIAL DAMAGES, HOWEVER CAUSED AND REGARDLESS OF THE THEORY OF LIABILITY, ARISING OUT OF ANY USE OF THIS DOCUMENT, EVEN IF NVIDIA HAS BEEN ADVISED OF THE POSSIBILITY OF SUCH DAMAGES. Notwithstanding any damages that customer might incur for any reason whatsoever, NVIDIA's aggregate and cumulative liability towards customer for the products described herein shall be limited in accordance with the Terms of Sale for the product.

Trademarks

NVIDIA, the NVIDIA logo, and Mellanox are trademarks and/or registered trademarks of NVIDIA Corporation and/or its affiliates in the U.S. and in other countries. Other company and product names may be trademarks of the respective companies with which they are associated.

Copyright

© 2026 NVIDIA Corporation & affiliates. All Rights Reserved.

